

YOKE®

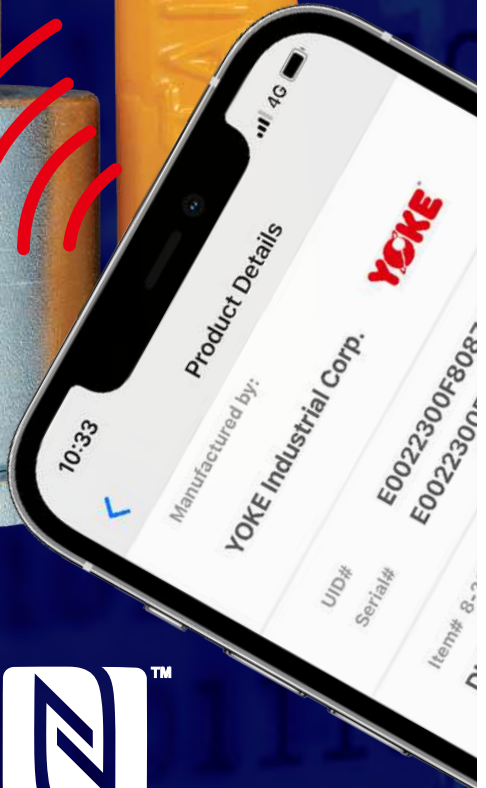



Digital Chip embedded
with Certificate
for serial Traceability



YOKE Go Digital !

YOKE's Digital Yellow Point makes product traceability and Pre-use Check the most simple task ever.

You can obtain and share information through the third party App, RiConnect, by NFC enabled smart phone. Product information, Safe Use Instructions and manufacturer's Certificate (EC Declaration of Conformity/ UK Declaration of Conformity/Declaration of Conformity or Certificate of Conformance or Manufacturer Certificate) can be retrieved simply with a smart phone or tablet.

The unique design of the proprietary wafer-antenna Digital Chip construction, enables Smart phone NFC and RFID Pre-use Check inspection to be more intuitive and efficient.

Tech for Safety!









Yellow Point

Quality Management System and Product Type Approval:



www.yoke.net/thirdpartycertificate

Statement of LIMITED WARRANTY

Purchaser and YOKE expressly agree that YOKE's warranty with respect to sale of its products is LIMITED solely to YOKE's choice of repair, replacement or refund of the purchase price of any product.

Purchaser and YOKE expressly agree that the remedies provided in this section are the purchaser's exclusive remedies in connection with the purchase or use of the product. Purchaser and YOKE expressly agree that in no event shall YOKE be liable for any incidental or consequential damages in connection with the purchase or use of the product.

All other warranties, including express warranties and the implied warranties of merchantability and fitness for a particular purpose are hereby disclaimed. Purchaser hereby waives all other warranties, rights and remedies arising by law or otherwise including, but not limited to, express warranties, the implied warranty of merchantability, any implied warranties arising from course of performance, course of dealing or usage of trade, and implied warranty of fitness for a particular purpose. Additionally, yoke hereby disclaims any of its obligations or liabilities arising from statute, warranty, contract, tort or negligence. Any modification made to yoke products will void the limited warranty where applicable, and will also void any third party accreditations that may apply such as abs, dnv, etc.

Complete Agreement: This Warranty between purchaser and YOKE is complete. All prior or contemporaneous discussions, representations and/or understanding are merged into this Warranty.

All prior or contemporaneous agreements between the parties are superseded by this Warranty. Choice of Law: Any dispute about the interpretation of this Warranty shall be governed by the laws of Taiwan, The Republic of China.

The Period of Warranty: Shall start from the date of delivery of the product to the customer and shall cover a period of 12 months.

Resolution of Disputes: Purchaser and YOKE expressly agree that any dispute arising out of the purchase, use or operation of the purchased product shall, upon written notice to the other party, be resolved through binding arbitration. The arbitration shall be governed by the then existing rules of the Arbitration Association of The Republic of China. The location of any arbitration shall be Taichung, Taiwan, The Republic of China. The substantive laws of The Republic of China shall govern the arbitration to the extent they are not in conflict with the then existing rules of the Arbitration Association of The Republic of China. In no event shall YOKE be liable for incidental or consequential damages as part of the arbitration award. The award, decision, or filing rendered by the arbitration shall be final, and judgment may be entered upon it in accordance with the applicable law in any court having appropriate jurisdiction.

YOKE INDUSTRIAL CORP.



YOKE YP Size & WLL Chart (Metric Thread)



Thread	8-211		8-231		8-203		8-251		8-271		8-291K		8-S291			
	WLL (t)	Wiegth (kg)	WLL (t)	Wiegth (kg)	WLL (t)	Wiegth (kg)	WLL (t)	Wiegth (kg)	WLL (t)	Wiegth (kg)	WLL (t)	Wiegth (kg)	WLL (t)	Wiegth (kg)		
M 6											0.10	0.10				
M 8	0.30	0.30	0.50	0.20	0.50	0.40	0.30	0.30	0.40	0.20	0.30	0.10				
M10	0.63	0.40	0.70	0.30	0.55	0.50	0.50	0.40	0.60	0.20	0.40	0.10				
M12	1.00	0.50	1.00	0.30	1.30	1.70	0.70	0.40	0.70	0.30	0.75	0.20	0.50	0.20		
M14	1.20	0.50	1.50	0.90			1.00	0.40								
M16	1.50	0.60	2.00	0.90	2.40	1.80	1.40	0.50	1.50	0.50	1.50	0.40	1.00	0.30		
M18	2.00	1.30	2.50	1.90												
M20	2.50	1.60	3.00	1.10	2.70	1.80	1.70	0.50	2.50	1.00	2.30	0.60	2.00	0.60		
					3.75	4.00	2.50	1.00								
M24	4.00	1.90	5.00	2.70	5.25	4.20	1.70	0.50	4.00	2.20	3.20	1.10	2.50	1.00		
							4.00	1.50								
M27	4.00	2.90	5.60	4.70												
M30	5.00	3.10	7.80	5.10	8.75	6.60	4.00	1.50			4.50	2.10				
							6.70	2.50	6.00	4.50						
							8.00	3.70	6.70	4.50						
M36	7.00	3.10	10.00	5.50	10.00	6.90	10.00	3.90	10.00	4.60	7.00	3.70				
							8.00	5.90	12.50	10.20	12.50	15.00				
											13.75	15.00				
M42	10.00	6.30	15.60	10.60	15.60	16.00	12.50	4.00	13.00	5.50	9.00	5.80				
	15.00	10.90					13.00	7.40								
M45							12.50	4.10								
							17.00	7.50								
M48	20.00	12.10	20.00	12.00	16.90	16.00	12.50	4.40	14.00	6.10	12.00	8.60				
							17.00	7.70								
M52							17.00	7.90	20.00	10.50						
M56		13.10	22.00	14.30			18.00	8.10	20.00	10.70	16.00	11.00				
M64		15.50	22.50	16.60			20.00	9.30	20.00	11.60	18.00	11.80				
							28.00	16.40								
M72							28.00	17.70	40.00	30.60						
							35.00	24.80								
							40.00	30.10								
M80							35.00	25.30								
							40.00	31.90	40.00	31.60						
							35.00	27.80								
M90							40.00	34.20	40.00	33.90						
							40.00	35.20								
M100							40.00									

* Design Factor 4:1



YOKE YP Size & WLL Chart (UNC Thread)



Thread	8-212		8-232		8-204		8-252		8-272		8-292K	
	WLL (t)	Wieght (kg)	WLL (t)	Wieght (kg)	WLL (t)	Wieght (kg)	WLL (t)	Wieght (kg)	WLL (t)	Wieght (kg)	WLL (t)	Wieght (kg)
5/16					0.45	0.90					0.30	0.30
3/8					0.56	0.90	0.50	1.00			0.40	0.30
1/2	1.00	1.00	1.00	0.60	1.38	3.70	0.70	1.00	0.70	0.70	0.75	0.50
5/8	1.50	1.30	2.00	2.00	2.25	4.00	1.40	1.00	1.50	1.20	1.50	0.90
3/4					2.75	4.00						
	2.50	2.90	3.00	2.10	3.88	8.80	2.50	2.10	2.00	1.20	2.30	1.40
7/8	2.50	2.80	3.75	5.00	4.50	9.30			2.50	2.20	2.30	1.50
1	4.00	4.30	5.00	3.40	5.63	9.50	4.00	3.30	4.00	4.80	3.20	2.50
1 1/4	5.00	6.80					6.70	5.30				
			7.81	11.20	8.50	14.50	8.00	8.10	6.00	9.90	4.50	4.70
1 1/2	8.00	12.90	12.5	22.30	13.63	35.20	10.00	8.30	10.00	10.00	7.00	8.70
1 3/4	15.00	24.50					12.50	8.80	13.00	12.10	9.00	12.70
2	20.00	27.20					12.50	9.70	14.00	13.50		
			20.00	28.70	17.00	35.20	17.00	16.70			12.00	19.60
2 1/4							18.00	17.80	20.00	23.10		
2 1/2							20.00	19.60				
							28.00	36.10	20.00	23.50		
3												
3 1/2							35.00	55.70				
4												

* Design Factor 4:1



Quality Control, Testing, and Detecting during manufacturing

YOKE runs a constant and strict production facility with quality control in every manufacturing stage from raw materials to the completed product. YOKE is an ISO 9001 certified company and has Type Approval by the major international authorities from Deutsche Gesetzliche Unfallversicherung (DGUV) , ABS, API, and DNV which ensure the quality research and development (R&D) department and unsurpassed product engineering.

Magnaflux Crack Detection:

All forged components are individually magnaflux detected after heat treatment.

Proof Load Testing:

YOKE Yellow Points are proof load qualified to 2.5 times the Working Load Limit within 1% permanent deformation.

Dynamic Fatigue Testing:

Batch samples of YOKE Yellow Points are Dynamic Fatigue Tested to 20,000 cycles at 1.5 times the Working Load Limit.

Ultimate Breaking Load Testing:

Batch samples are tested in a static tensile testing machine until failure. Minimum ultimate force equals to the Working Load Limit times safety factor.

Spectrographic Analysis:

To assure of the proper metallurgy content of all raw materials.

Safety is our first priority™

- Quality, Reliability, Innovation -

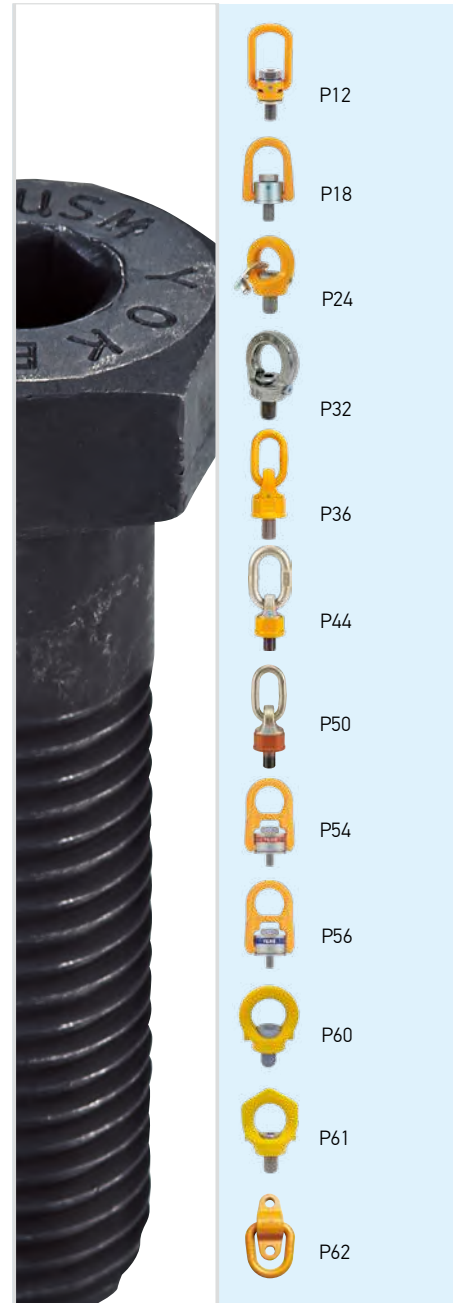

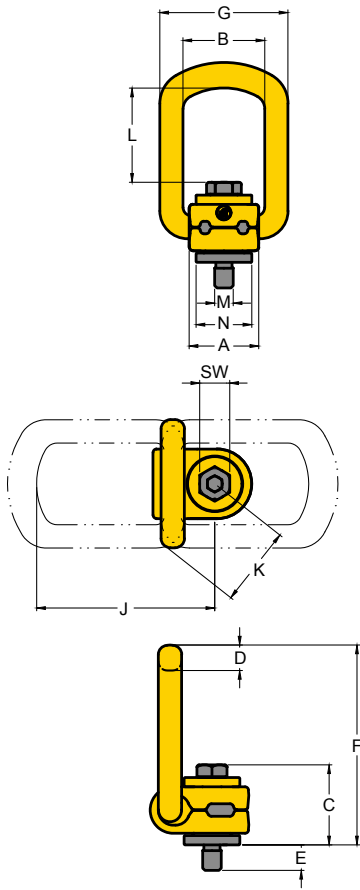

Digital Chip embedded with Certificate for serial Traceability

- Rotates through 360° and pivot 90°.
- Manufactured from alloy steel, quenched and tempered.
- Tested in accordance with EN1677-1.
- Certified by DGUV GS-0A 15-04.
- Load rated parts are 100% magnaflux crack detected.
- Individual forged parts and cap screw are traceable to Test Certification.
- Bolts are Metric thread.
- Proof tested to 2.5 times the WLL.
- Fatigue rated to 20,000 cycles at 1.5 times the WLL.
- All YOKE Lifting points meet or exceed all the requirements of ASME B30.26.
- Quick and simple assembly, just a tapped hole is required.

- » United States Patent: 10607128
- » UK Patent: 3627396
- » German Patent: 602018032891.2
- » Italy Patent: 3627396
- » Japan Patent: 3219858
- » China Patent: ZL 2012 1 0131962.1
- » Taiwan Patent: 1468602

Digital Lifting Point Metric Thread (8-211)

Item No.	Working Load Limit	Thread version			Dimensions										Torque in Nm	N.W. kg	
		M	E	Pitch	A	B	C	D	F	G	SW	J	K	L			N
	tonnes	mm	mm	DIN13	mm												
8-211-003	0.30	M 8	12	1.25	30	35	35	11	86	55	13	77	34	41	24	30	0.3
8-211-006	0.63	M 10	15	1.50	30	35	36	11	86	55	17	77	34	40	24	60	0.4
8-211-010	1.00	M 12	18	1.75	33	38	44	14	99	57	19	89	38	42	31	100	0.5
8-211-012	1.20	M 14	21	2.00	33	38	45	14	99	57	22	89	38	40	31	120	0.5
8-211-015	1.50	M 16	24	2.00	33	38	46	14	99	57	24	89	38	40	31	150	0.6
8-211-020	2.00	M 18	27	2.50	50	54	57	16	143	82	30	132	53	70	45	200	1.3
8-211-025	2.50	M 20	30	2.50	50	54	56	16	143	82	30	132	53	70	49	250	1.6
8-211-040	4.00	M 24	36	3.00	50	54	59	16	143	82	36	132	53	67	45	400	1.9
8-211-042	4.00	M 27	38	3.00	60	65	79	23	171	99	41	153	64	69	59	400	2.9
8-211-050	5.00	M 30	49	3.50	60	65	81	23	171	99	46	153	64	67	59	500	3.1
8-211-070	7.00	M 36	56	4.00	60	65	75	23	171	99	55	153	64	74	59	700	3.1
8-211-080	8.00	M 36	62	4.00	77	85	101	27	225	124	55	205	80	97	69	800	5.9
8-211-100	10.00	M 42	72	4.50	77	85	104	27	225	124	65	205	80	94	69	1000	6.3
8-211-150	15.00	M 42	63	4.50	95	104	112	36	258	158	65	230	99	110	98	1500	10.9
8-211-200	20.00	M 48	72	5.00	95	104	120	36	260	158	75	230	99	104	98	2000	12.1

* Design Factor 4:1





Kind of attachment																				
	Number of legs	Load direction	1	2	1	2	2	2	2	3-4	3-4	3-4	3-4	3-4	3-4	3-4	3-4	3-4	3-4	3-4
Item No.	Thread	WLL(t)																		
8-211-003	M 8	0.30	0.60	0.30	0.60	0.42	0.30	0.30	0.63	0.45	0.30	0.63	0.45	0.30	0.63	0.45	0.30	0.63	0.45	0.30
8-211-006	M 10	0.63	1.26	0.63	1.26	0.88	0.63	0.63	1.32	0.95	0.63	1.32	0.95	0.63	1.32	0.95	0.63	1.32	0.95	0.63
8-211-010	M 12	1.00	2.00	1.00	2.00	1.40	1.00	1.00	2.10	1.50	1.00	2.10	1.50	1.00	2.10	1.50	1.00	2.10	1.50	1.00
8-211-012	M 14	1.20	2.40	1.20	2.40	1.68	1.20	1.20	2.52	1.80	1.20	2.52	1.80	1.20	2.52	1.80	1.20	2.52	1.80	1.20
8-211-015	M 16	1.50	3.00	1.50	3.00	2.10	1.50	1.50	3.15	2.25	1.50	3.15	2.25	1.50	3.15	2.25	1.50	3.15	2.25	1.50
8-211-020	M 18	2.00	4.00	2.00	4.00	2.80	2.00	2.00	4.20	3.00	2.00	4.20	3.00	2.00	4.20	3.00	2.00	4.20	3.00	2.00
8-211-025	M 20	2.50	5.00	2.50	5.00	3.50	2.50	2.50	5.25	3.75	2.50	5.25	3.75	2.50	5.25	3.75	2.50	5.25	3.75	2.50
8-211-040	M 24	4.00	8.00	4.00	8.00	5.60	4.00	4.00	8.40	6.00	4.00	8.40	6.00	4.00	8.40	6.00	4.00	8.40	6.00	4.00
8-211-042	M 27	4.00	8.00	4.00	8.00	5.60	4.00	4.00	8.40	6.00	4.00	8.40	6.00	4.00	8.40	6.00	4.00	8.40	6.00	4.00
8-211-050	M 30	5.00	10.00	5.00	10.00	7.00	5.00	5.00	10.50	7.50	5.00	10.50	7.50	5.00	10.50	7.50	5.00	10.50	7.50	5.00
8-211-070	M 36	7.00	14.00	7.00	14.00	9.80	7.00	7.00	14.70	10.50	7.00	14.70	10.50	7.00	14.70	10.50	7.00	14.70	10.50	7.00
8-211-080	M 36	8.00	16.00	8.00	16.00	11.20	8.00	8.00	16.80	12.00	8.00	16.80	12.00	8.00	16.80	12.00	8.00	16.80	12.00	8.00
8-211-100	M 42	10.00	20.00	10.00	20.00	14.00	10.00	10.00	21.00	15.00	10.00	21.00	15.00	10.00	21.00	15.00	10.00	21.00	15.00	10.00
8-211-150	M 42	15.00	30.00	15.00	30.00	21.00	15.00	15.00	31.50	22.50	15.00	31.50	22.50	15.00	31.50	22.50	15.00	31.50	22.50	15.00
8-211-200	M 48	20.00	40.00	20.00	40.00	28.00	20.00	20.00	42.00	30.00	20.00	42.00	30.00	20.00	42.00	30.00	20.00	42.00	30.00	20.00

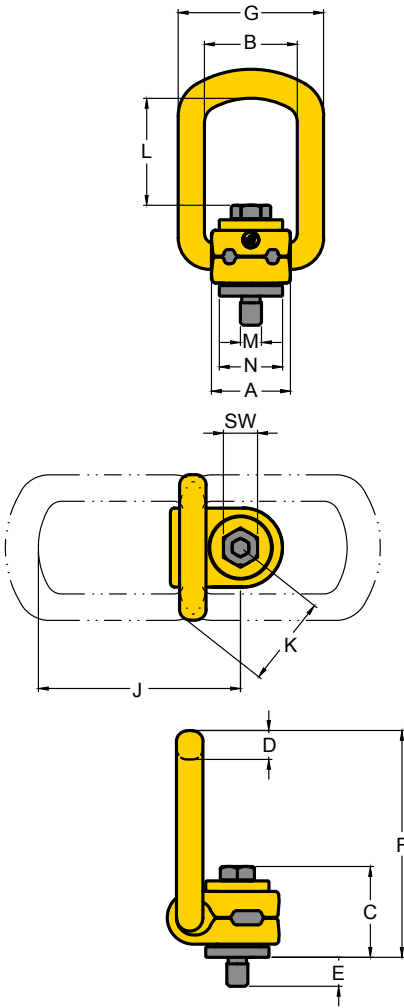

Digital Chip embedded with Certificate for serial Traceability

- Rotates through 360° and pivots 90°.
- Manufactured from alloy steel, quenched and tempered.
- Tested in accordance with EN1677-1.
- Load rated parts are 100% magnaflux crack detected.
- Individual forged parts and cap screw are traceable to Test Certification.
- Bolts are UNC thread.
- Proof tested to 2.5 times the WLL.
- Fatigue rated to 20,000 cycles at 1.5 times the WLL.
- All YOKE Lifting points meet or exceed all the requirements of ASME B30.26.
- Quick and simple assembly, just a tapped hole is required.

- » United States Patent: 10607128
- » UK Patent: 3627396
- » German Patent: 602018032891.2
- » Italy Patent: 3627396
- » Japan Patent: 3219858
- » China Patent: ZL 2012 1 0131962.1
- » Taiwan Patent: 1468602

Digital Lifting Point

UNC Thread (8-212)

Item No.	Working Load Limit	Thread version		Dimensions													Torque in	N.W.
		M	E	TPI	A	B	C	D	F	G	SW	J	K	L	N			
		tonnes	inch	inch	mm													
8-212-010	1.0	1/2	0.94	13.0UNC	1.30	1.48	1.73	0.53	3.90	2.24	3/4	3.49	1.49	1.62	1.22	100	1.0	
8-212-015	1.5	5/8	1.14	11.0UNC	1.30	1.48	1.81	0.53	3.90	2.24	15/16	3.49	1.49	1.56	1.22	150	1.3	
8-212-020	2.5	3/4	1.46	10.0UNC	1.97	2.13	2.16	0.65	5.62	3.22	1 1/8	5.23	2.09	2.77	1.93	200	2.9	
8-212-025	2.5	7/8	1.46	9.0UNC	1.97	2.13	2.24	0.65	5.62	3.22	1 5/16	5.23	2.09	2.69	1.93	250	2.8	
8-212-040	4.0	1	1.61	8.0UNC	1.97	2.13	2.34	0.65	5.62	3.22	1 1/2	5.23	2.09	2.63	1.77	400	4.3	
8-212-050	5.0	1 1/4	2.11	7.0UNC	2.36	2.56	3.21	0.89	6.70	3.90	1 7/8	6.00	2.53	2.60	2.32	500	6.8	
8-212-080	8.0	1 1/2	2.44	6.0UNC	3.03	3.35	4.01	1.04	8.85	4.88	2 1/4	8.04	3.15	3.80	2.72	800	12.9	
8-212-150	15.0	1 3/4	2.60	5.0UNC	3.74	4.09	4.41	1.42	10.16	6.22	2 5/8	9.07	3.88	4.33	3.86	1500	24.5	
8-212-200	20.0	2	2.80	4.5UNC	3.74	4.09	4.72	1.42	10.24	6.22	3	9.07	3.88	4.09	3.86	2000	27.2	

* Design Factor 4:1





Kind of attachment											
Number of legs	Thread	1	2	1	2	2	2	2	3-4	3-4	3-4
Item No.	Inch	WLL(t)									
8-212-010	1/2	1.0	2	1.0	2	1.4	1.0	1.0	2.10	1.50	1.0
8-212-015	5/8	1.5	3	1.5	3	2.1	1.5	1.5	3.15	2.25	1.5
8-212-020	3/4	2.5	5	2.5	5	3.5	2.5	2.5	5.25	3.75	2.5
8-212-025	7/8	2.5	5	2.5	5	3.5	2.5	2.5	5.25	3.75	2.5
8-212-040	1	4.0	8	4.0	8	5.6	4.0	4.0	8.40	6.00	4.0
8-212-050	1 1/4	5.0	10	5.0	10	7.0	5.0	5.0	10.5	7.50	5.0
8-212-080	1 1/2	8.0	16	8.0	16	11.2	8.0	8.0	16.8	12.0	8.0
8-212-150	1 3/4	15.0	30	15.0	30	21.0	15.0	15.0	31.5	22.5	15.0
8-212-200	2	20.0	40	20.0	40	28.0	20.0	20.0	42.0	30.0	20.0

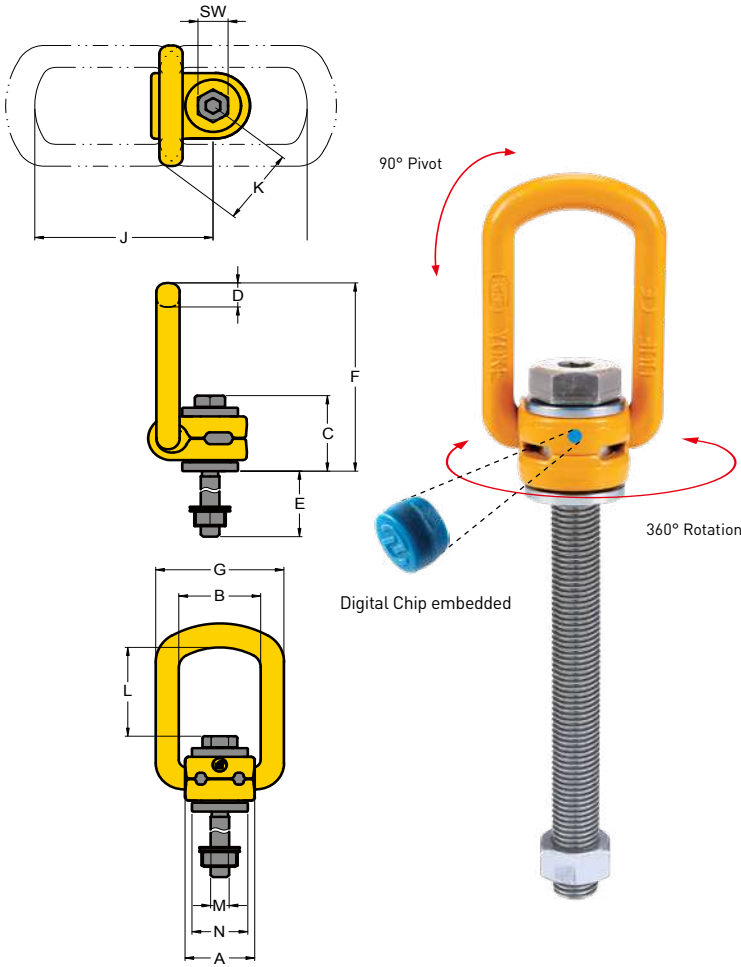

- Rotates through 360° and pivots 90°.
- Manufactured from alloy steel, quenched and tempered.
- Tested in accordance with EN1677-1.
- Load rated parts are 100% magnaflux crack detected.
- Individual forged parts and cap screw are traceable to Test Certification.
- Bolts are Metric thread.
- Proof tested to 2.5 times the WLL.
- Fatigue rated to 20,000 cycles at 1.5 times the WLL.
- All YOKE Lifting points meet or exceed all the requirements of ASME B30.26.
- Quick and simple assembly, just a tapped hole is required.

- » United States Patent: 10607128
- » UK Patent: 3627396
- » German Patent: 602018032891.2
- » Italy Patent: 3627396
- » Japan Patent: 3219858

- » China Patent: ZL 2012 1 0131962.1
- » Taiwan Patent: I468602

Digital Chip embedded with Certificate for serial Traceability

Digital Lifting Point, Long Bolt Metric Thread (8-211L)

Item No.	Working Load Limit tonnes	Thread version			Dimensions											Torque in Nm	N.W. kg
		M	E	Pitch	A	B	C	D	F	G	SW	J	K	L	N		
		mm	mm	DIN13	mm												
8-211-003/105L	0.30	M 8	76	1.25	30	35	35	11	86	55	13	77	34	41	24	30	0.4
8-211-006/125L	0.63	M 10	96	1.50	30	35	36	11	86	55	17	78	34	40	24	60	0.4
8-211-010/150L	1.00	M 12	114	1.75	33	38	44	14	99	57	19	89	38	42	31	100	0.5
8-211-015/185L	1.50	M 16	149	2.00	33	38	46	14	99	57	24	89	38	40	31	150	0.7
8-211-025/230L	2.50	M 20	187	2.50	50	54	56	16	142	82	30	132	53	70	49	250	1.7
8-211-040/265L	4.00	M 24	221	3.00	50	54	59	16	143	82	36	132	53	67	45	400	2.0
8-211-050/340L	5.00	M 30	279	3.50	60	65	81	23	170	99	46	153	64	67	59	500	4.3
8-211-080/300L	8.00	M 36	222	4.00	77	85	101	27	225	124	55	205	80	97	69	800	6.9
8-211-100/350L	10.00	M 42	272	4.50	77	85	104	27	225	124	65	204	79	94	69	1000	7.9
8-211-150/350L	15.00	M 42	264	4.50	95	104	112	36	258	158	65	229	98	110	98	1500	13.5
8-211-200/385L	20.00	M 48	295	5.00	95	104	120	36	260	158	75	230	99	104	98	2000	15.5

* Design Factor 4:1





Kind of attachment											
Number of legs		1	2	1	2	2	2	2	3-4	3-4	3-4
Load direction		0°	0°	90°	90°	0-45°	45°- 60°	unsymm.	0 - 45°	45°- 60°	unsymm.
Item No.	Thread	WLL(t)									
8-211-003/105L	M 8	0.30	0.60	0.30	0.60	0.42	0.30	0.30	0.63	0.45	0.30
8-211-006/125L	M10	0.63	1.26	0.63	1.26	0.88	0.63	0.63	1.32	0.95	0.63
8-211-010/150L	M12	1.00	2.00	1.00	2.00	1.40	1.00	1.00	2.10	1.50	1.00
8-211-015/185L	M16	1.50	3.00	1.50	3.00	2.10	1.50	1.50	3.15	2.25	1.50
8-211-025/230L	M20	2.50	5.00	2.50	5.00	3.50	2.50	2.50	5.25	3.75	2.50
8-211-040/265L	M24	4.00	8.00	4.00	8.00	5.60	4.00	4.00	8.40	6.00	4.00
8-211-050/340L	M30	5.00	10.00	5.00	10.00	7.00	5.00	5.00	10.50	7.50	5.00
8-211-080/300L	M36	8.00	16.00	8.00	16.00	11.20	8.00	8.00	16.80	12.00	8.00
8-211-100/350L	M42	10.00	20.00	10.00	20.00	14.00	10.00	10.00	21.00	15.00	10.00
8-211-150/350L	M42	15.00	30.00	15.00	30.00	21.00	15.00	15.00	31.50	22.50	15.00
8-211-200/385L	M48	20.00	40.00	20.00	40.00	28.00	20.00	20.00	42.00	30.00	20.00

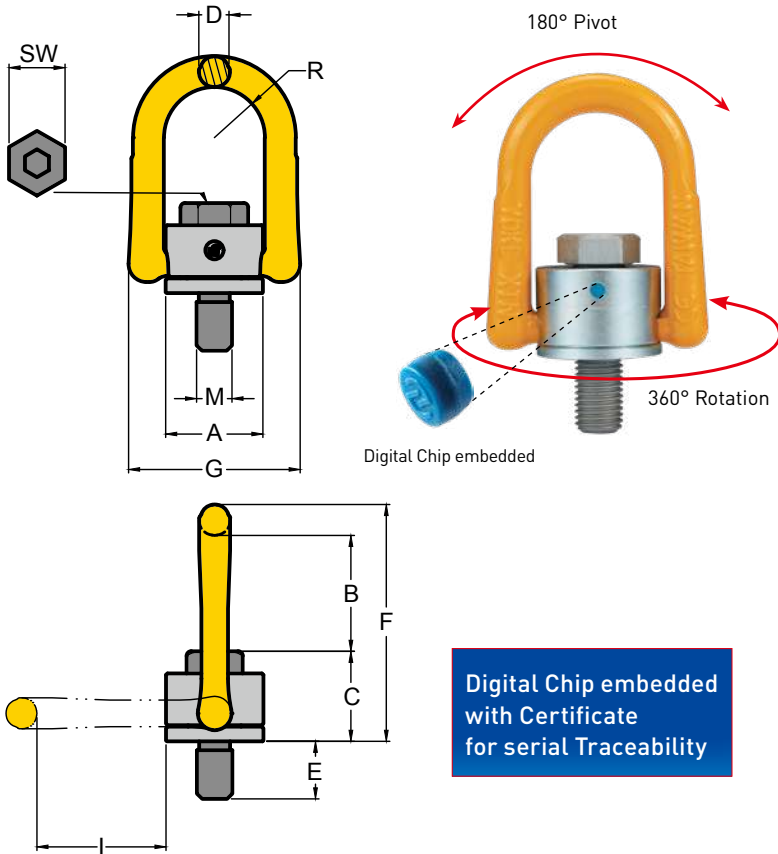

- Rotates through 360° and pivots 180°, and simultaneously allows lifting from any direction.
- Manufactured from forged alloy steel, quenched and tempered.
- Tested in accordance with EN1677-1.
- Load rated parts are 100% magnaflux crack detected.
- Individual forged parts and cap screw are traceable to Test Certification.
- Bolts are Metric thread.
- Proof tested to 2.5 times the WLL.
- Fatigue rated to 20,000 cycles at 1.5 times the WLL.
- All YOKE Lifting points meet or exceed all the requirements of ASME B30.26.
- Quick and simple assembly, just a tapped hole is required.

- » United States Patent: 10607128
- » UK Patent: 3627396
- » German Patent: 602018032891.2
- » Italy Patent: 3627396
- » Japan Patent: 3219858
- » China Patent: ZL 2012 1 0131962.1
- » Taiwan Patent: 1468602

Digital Anchor Point Metric Thread (8-231)

Item No.	Working Load Limit tonnes	Thread version			Dimensions									Torque in Nm	N.W. kg
		M	E	Pitch	A	B	C	D	F	G	R	SW	I		
		mm	mm	DIN13	mm	mm	mm	mm	mm	mm	mm	mm	mm		
8-231-005	0.5	M 8	12	1.25	33	42	28	11	80	58	17	13	44	30	0.2
8-231-007	0.7	M 10	15	1.50	33	41	29	11	80	58	17	17	44	60	0.3
8-231-010	1.0	M 12	20	1.75	33	39	31	11	80	58	17	19	44	100	0.3
8-231-015	1.5	M 14	21	2.00	50	56	45	17	116	90	27	22	63	120	0.9
8-231-020	2.0	M 16	24	2.00	50	54	46	17	116	90	27	24	63	150	0.9
8-231-025	2.5	M 18	27	2.50	65	77	57	20	155	108	34	30	86	200	1.9
8-231-030	3.0	M 20	34	2.50	51	52	49	17	116	90	27	30	63	250	1.1
8-231-050	5.0	M 24	36	3.00	72	81	59	25	163	126	37	36	88	400	2.7
8-231-056	5.6	M 27	38	3.00	87	96	79	30	204	148	46	41	110	400	4.7
8-231-078	7.8	M 30	48	3.50	87	94	81	30	204	148	46	46	110	500	5.1
8-231-100	10.0	M 36	54	4.00	87	90	85	30	204	148	46	55	110	1000	5.6
8-231-125	12.5	M 36	56	4.00	110	112	98	36	248	188	57	55	128	1000	10.2
8-231-156	15.6	M42	63	4.50	110	101	108	36	248	188	57	65	128	1500	10.6
8-231-200	20.0	M48	72	5.00	110	97	112	36	248	188	57	75	128	2000	12.0
8-231-220	22.0	M56	84	5.50	123	116	121	36	274	202	64	85	145	2100	14.3
8-231-225	22.5	M64	100	6.00	123	111	126	36	274	202	64	95	146	2200	16.6

* Design Factor 4:1



Kind of attachment											
Number of legs		1	2	1	2	2	2	2	3-4	3-4	3-4
Load direction		0°	0°	90°	90°	0-45°	45°- 60°	unsymm.	0 - 45°	45°- 60°	unsymm.
Item No.	Thread	WLL(t)									
8-231-005	M 8	0.8	1.6	0.5	1.0	0.7	0.5	0.5	1.10	0.80	0.5
8-231-007	M 10	1.2	2.4	0.7	1.4	1.0	0.7	0.7	1.50	1.10	0.7
8-231-010	M 12	1.5	3.0	1.0	2.0	1.4	1.0	1.0	2.10	1.50	1.0
8-231-015	M 14	2.4	4.8	1.5	3.0	2.1	1.5	1.5	3.20	2.30	1.5
8-231-020	M 16	3.2	6.4	2.0	4.0	2.8	2.0	2.0	4.20	3.00	2.0
8-231-025	M 18	5.0	10.0	2.5	5.0	3.5	2.5	2.5	5.30	3.80	2.5
8-231-030	M 20	4.5	9.0	3.0	6.0	4.2	3.0	3.0	6.30	4.50	3.0
8-231-050	M 24	9.0	18.0	5.0	10.0	7.0	5.0	5.0	10.50	7.50	5.0
8-231-056	M 27	9.5	19.0	5.6	11.2	7.8	5.6	5.6	11.80	8.40	5.6
8-231-078	M 30	12.0	24.0	7.8	15.6	10.9	7.8	7.8	16.40	11.70	7.8
8-231-080	M36	13.0	26.0	8.0	16.0	11.2	8.0	8.0	16.80	12.00	8.0
8-231-100	M36	13.0	26.0	10.0	20.0	14.0	10.0	10.0	21.00	15.00	10.0
8-231-125	M 36	14.0	28.0	12.5	25.0	17.5	12.5	12.5	26.30	18.80	12.5
8-231-156	M 42	16.0	32.0	15.6	31.2	21.8	15.6	15.6	32.80	23.40	15.6
8-231-200	M 48	20.0	40.0	20.0	40.0	28.0	20.0	20.0	42.00	30.00	20.0
8-231-220	M 56	22.0	44.0	22.0	44.0	30.8	22.0	22.0	46.20	33.00	22.0
8-231-225	M 64	22.5	45.0	22.5	45.0	31.5	22.5	22.5	47.25	33.75	22.5

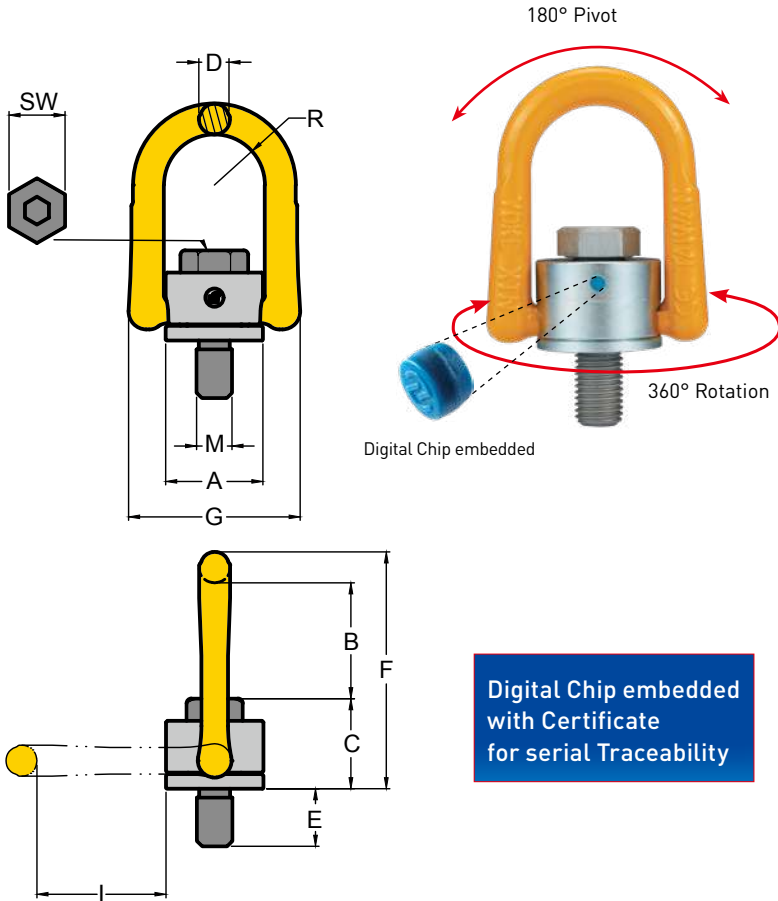

Digital Chip embedded
with Certificate
for serial Traceability

- Rotates through 360° and pivots 180°, and simultaneously allows lifting from any direction.
- Manufactured from forged alloy steel, quenched and tempered.
- Tested in accordance with EN1677-1.
- Load rated parts are 100% magnaflux crack detected.
- Individual forged parts and cap screw are traceable to Test Certification.
- Bolts are UNC thread.
- Proof tested to 2.5 times the WLL.
- Fatigue rated to 20,000 cycles at 1.5 times the WLL.
- All YOKE Lifting points meet or exceed all the requirements of ASME B30.26.
- Quick and simple assembly, just a tapped hole is required.

- » United States Patent: 10607128
- » UK Patent: 3627396
- » German Patent: 602018032891.2
- » Italy Patent: 3627396
- » Japan Patent: 3219858
- » China Patent: ZL 2012 1 0131962.1
- » Taiwan Patent: I468602

Digital Anchor Point

UNC Thread (8-232)

Item No.	Working Load Limit	Thread version			Dimensions								Torque in		N.W.	
		M	E	TPI	A	B	C	D	F	G	R	SW	I	Nm		lbs
	tonnes	inch	inch						inch							
8-232-010	0.80	1/2	0.81	13 UNC	1.30	1.55	1.20	0.41	3.16	2.29	0.67	3/4	1.72	100	0.6	
8-232-020	1.60	5/8	1.13	11 UNC	1.97	2.14	1.81	0.65	4.56	3.54	1.06	15/16	2.48	150	2.0	
8-232-030	2.40	3/4	1.54	10 UNC	2.01	2.06	1.89	0.65	4.56	3.54	1.06	1 1/8	2.46	250	2.1	
8-232-038	3.00	7/8	1.42	9 UNC	2.81	3.24	2.28	0.98	6.42	4.94	1.47	1 5/16	3.45	300	5.0	
8-232-050	4.00	1	1.61	8 UNC	2.81	3.18	2.34	0.98	6.42	4.94	1.47	1 1/2	3.45	400	3.4	
8-232-078	6.25	1 1/4	2.09	7 UNC	3.43	3.65	3.23	1.16	8.02	5.82	1.79	1 7/8	4.31	500	11.2	
8-232-125	10.00	1 1/2	2.40	6 UNC	4.33	4.38	4.05	1.42	9.80	7.40	2.24	2 1/4	5.04	800	22.3	
8-232-200	16.00	2	3.00	4.5 UNC	4.33	3.84	4.53	1.42	9.80	7.40	2.24	3	4.88	2000	28.7	

* Design Factor 5:1





Kind of attachment											
Number of legs	Thread	1	2	1	2	2	2	2	3-4	3-4	3-4
Load direction	Thread	0°	0°	90°	90°	0-45°	45°- 60°	unsymm.	0 - 45°	45°- 60°	unsymm.
Item No.	Inch	WLL(t)									
8-232-010	1/2	1.2	2.4	0.80	1.6	1.12	0.80	0.80	1.68	1.20	0.80
8-232-020	5/8	2.6	5.2	1.60	3.2	2.24	1.60	1.60	3.36	2.40	1.60
8-232-030	3/4	3.6	7.2	2.40	4.8	3.36	2.40	2.40	5.04	3.60	2.40
8-232-038	7/8	4.5	9.0	3.00	6.0	4.20	3.00	3.00	6.30	4.50	3.00
8-232-050	1	7.2	14.4	4.00	8.0	5.60	4.00	4.00	8.40	6.00	4.00
8-232-078	1 1/4	9.6	19.2	6.25	12.5	8.75	6.25	6.25	13.13	9.38	6.25
8-232-125	1 1/2	11.0	22.0	10.00	20.0	14.00	10.00	10.00	21.00	15.00	10.00
8-232-200	2	16.0	32.0	16.00	32.0	22.40	16.00	16.00	33.60	24.00	16.00

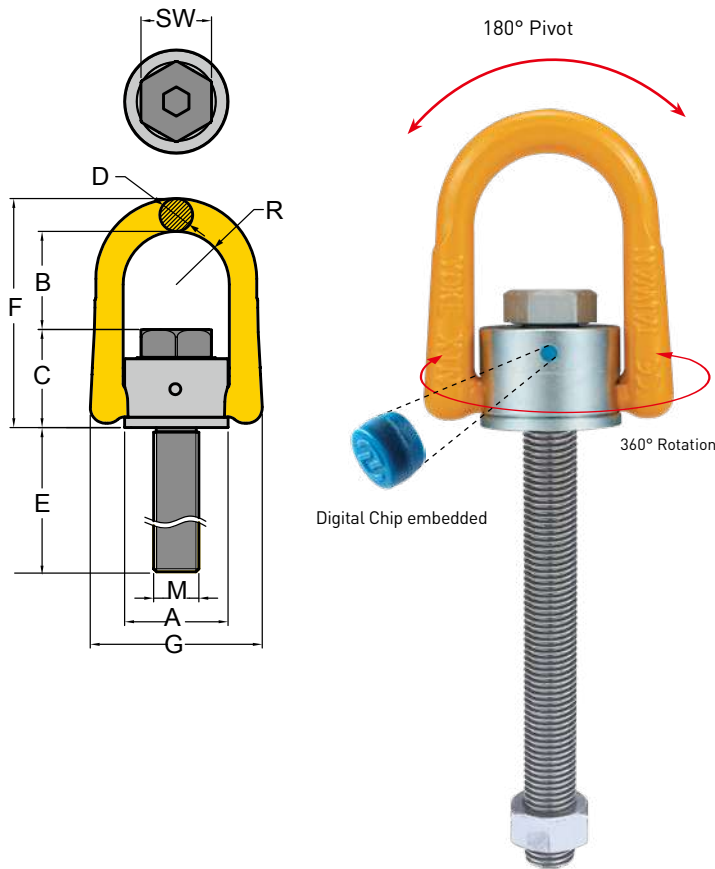

- Rotates through 360° and pivots 180°, and simultaneously allows lifting from any direction.
- Manufactured from forged alloy steel, quenched and tempered.
- Tested in accordance with EN1677-1.
- Load rated parts are 100% magnaflux crack detected.
- Individual forged parts and cap screw are traceable to Test Certification.
- Bolts are Metric thread.
- Proof tested to 2.5 times the WLL.
- Fatigue rated to 20,000 cycles at 1.5 times the WLL.
- All YOKE Lifting points meet or exceed all the requirements of ASME B30.26.
- Quick and simple assembly, just a tapped hole is required.

- » United States Patent: 10607128
- » UK Patent: 3627396
- » German Patent: 602018032891.2
- » Italy Patent: 3627396
- » Japan Patent: 3219858

- » China Patent: ZL 2012 1 0131962.1
- » Taiwan Patent: I468602

Digital Chip embedded with Certificate for serial Traceability

Digital Anchor Point, Long Bolt Metric Thread (8-231L)

Item No.	Working Load Limit tonnes	Thread version			Dimensions								Torque in		N.W. kg
		M	E	Pitch DIN13	A	B	C	D	F	G	R	SW	Nm		
8-231-005/105L	0.5	M 8	83	1.25	33	42	28	11	80	58	17	13	30	0.3	
8-231-007/125L	0.7	M 10	103	1.50	33	41	29	11	80	58	17	17	60	0.4	
8-231-010/150L	1.0	M 12	128	1.75	33	39	31	11	80	58	17	19	100	0.4	
8-231-020/185L	2.0	M 16	149	2.00	50	54	46	17	116	90	27	24	150	1.0	
8-231-030/230L	3.0	M 20	194	2.50	51	52	49	17	116	90	27	30	250	2.0	
8-231-050/265L	5.0	M 24	222	3.00	72	81	59	25	163	126	37	36	400	2.8	
8-231-078/340L	7.8	M 30	278	3.50	87	94	81	30	204	148	46	46	500	6.3	
8-231-125/300L	12.5	M 36	226	4.00	110	112	98	36	248	188	57	55	1000	10.6	
8-231-156/350L	15.6	M 42	268	4.50	110	101	108	36	248	188	57	65	1500	11.3	
8-231-200/385L	20.0	M 48	303	5.00	110	97	112	36	248	188	57	75	2000	13.3	

* Design Factor 4:1



Kind of attachment																				
	Number of legs	Load direction	1	2	1	2	2	2	2	2	3-4	3-4	3-4	3-4	3-4	3-4	3-4	3-4	3-4	3-4
Item No.	Thread	WLL(t)																		
8-231-005/105L	M 8	0.8	1.6	0.5	1.0	0.7	0.5	0.5	0.5	1.1	0.8	0.5								
8-231-007/125L	M10	1.2	2.4	0.7	1.4	1.0	0.7	0.7	0.7	1.5	1.1	0.7								
8-231-010/150L	M12	1.5	3.0	1.0	2.0	1.4	1.0	1.0	1.0	2.1	1.5	1.0								
8-231-020/185L	M16	3.2	6.4	2.0	4.0	2.8	2.0	2.0	2.0	4.2	3.0	2.0								
8-231-030/230L	M20	4.5	9.0	3.0	6.0	4.2	3.0	3.0	3.0	6.3	4.5	3.0								
8-231-050/265L	M24	9.0	18.0	5.0	10.0	7.0	5.0	5.0	5.0	10.5	7.5	5.0								
8-231-078/340L	M30	12.0	24.0	7.8	15.6	10.9	7.8	7.8	7.8	16.4	11.7	7.8								
8-231-125/300L	M36	14.0	28.0	12.5	25.0	17.5	12.5	12.5	12.5	26.3	18.8	12.5								
8-231-156/350L	M42	16.0	32.0	15.6	31.2	21.8	15.6	15.6	15.6	32.8	23.4	15.6								
8-231-200/385L	M48	20.0	40.0	20.0	40.0	28.0	20.0	20.0	20.0	42.0	30.0	20.0								



Kind of attachment																				
	Number of legs	Load direction	1	2	1	2	2	2	2	2	3-4	3-4	3-4	3-4	3-4	3-4	3-4	3-4	3-4	3-4
Item No.	Thread	WLL(t)																		
8-291K-001	M 6 NEW	0.5	1	0.10	0.2	0.14	0.10	0.10	0.10	0.21	0.15	0.10								
8-291K-003	M 8	1	2	0.30	0.6	0.42	0.30	0.30	0.63	0.45	0.30									
8-291K-004	M10	1	2	0.40	0.8	0.56	0.40	0.40	0.84	0.60	0.40									
8-291K-007	M12	2	4	0.75	1.5	1.00	0.75	0.75	1.58	1.12	0.75									
8-291K-015	M16	4	8	1.50	3.0	2.10	1.50	1.50	3.15	2.25	1.50									
8-291K-023	M20	6	12	2.30	4.6	3.20	2.30	2.30	4.83	3.45	2.30									
8-291K-032	M24	8	16	3.20	6.4	4.50	3.20	3.20	6.70	4.80	3.20									
8-291K-045	M30	12	24	4.50	9.0	6.30	4.50	4.50	9.40	6.70	4.50									
8-291K-070	M36	16	32	7.00	14.0	9.80	7.00	7.00	14.70	10.50	7.00									
8-291K-090	M42	24	48	9.00	18.0	12.60	9.00	9.00	18.90	13.50	9.00									
8-291K-120	M48	32	64	12.00	24.0	16.80	12.00	12.00	25.20	18.00	12.00									
8-291K-140	M56	34	68	16.00	32.0	22.40	16.00	16.00	33.60	24.00	16.00									
8-291K-150	M64	36	72	18.00	36.0	25.20	18.00	18.00	37.80	27.00	18.00									



Kind of attachment											
Number of legs	Thread	1	2	1	2	2	2	2	3-4	3-4	3-4
Load direction	Thread	0°	0°	90°	90°	0-45°	45°- 60°	unsymm.	0 - 45°	45°- 60°	unsymm.
Item No.	Inch	WLL(t)									
8-292K-003	5/16	1	2	0.30	0.6	0.42	0.30	0.30	0.63	0.45	0.30
8-292K-004	3/8	1	2	0.40	0.8	0.56	0.40	0.40	0.84	0.60	0.40
8-292K-007	1/2	2	4	0.75	1.5	1.00	0.75	0.75	1.58	1.12	0.75
8-292K-015	5/8	4	8	1.50	3.0	2.10	1.50	1.50	3.15	2.25	1.50
8-292K-023	3/4	6	12	2.30	4.6	3.20	2.30	2.30	4.83	3.45	2.30
8-292K-025	7/8	6	12	2.30	4.6	3.20	2.30	2.30	4.83	3.45	2.30
8-292K-032	1	8	16	3.20	6.4	4.50	3.20	3.20	6.70	4.80	3.20
8-292K-045	1 1/4	12	24	4.50	9.0	6.30	4.50	4.50	9.40	6.70	4.50
8-292K-070	1 1/2	16	32	7.00	14.0	9.80	7.00	7.00	14.70	10.50	7.00
8-292K-090	1 3/4	24	48	9.00	18.0	12.60	9.00	9.00	18.90	13.50	9.00
8-292K-120	2	32	64	12.00	24.0	16.80	12.00	12.00	25.20	18.00	12.00



Kind of attachment	A		A		B							
	G	G	G	G	G	G	G	G	G	G	G	G
Number of legs	1	2	1	2	2	2	2	2	3-4	3-4	3-4	
Load direction	0°	0°	90°	90°	0-45°	45°- 60°	unsymm.		0 - 45°	45°- 60°	unsymm.	
Item No.	Thread	WLL(t)										
8-291K-004/78L	M10	1	2	0.40	0.8	0.56	0.40	0.40	0.84	0.60	0.40	
8-291K-007/159L	M12	2	4	0.75	1.5	1.05	0.75	0.75	1.58	1.12	0.75	
8-291K-015/130L	M16	4	8	1.50	3.0	2.10	1.50	1.50	3.15	2.25	1.50	
8-291K-023/171L	M20	6	12	2.30	4.6	3.20	2.30	2.30	4.83	3.45	2.30	
8-291K-032/152L	M24	8	16	3.20	6.4	4.50	3.20	3.20	6.70	4.80	3.20	
8-291K-045/206L	M30	12	24	4.50	9.0	6.30	4.50	4.50	9.40	6.70	4.50	
8-291K-070/259L	M36	16	32	7.00	14.0	9.80	7.00	7.00	14.70	10.50	7.00	



Kind of attachment											
Number of legs	1	2	1	2	2	2	2	3-4	3-4	3-4	
Load direction	0°	0°	90°	90°	0-45°	45°-60°	unsymm.	0 - 45°	45°- 60°	unsymm.	
Thread											
Item No.	Inch	WLL(t)									
8-292K-007/157L	1/2	2	4	0.75	1.5	1.05	0.75	0.75	1.58	1.12	0.75
8-292K-015/129L	5/8	4	8	1.50	3.0	2.10	1.50	1.50	3.15	2.25	1.50
8-292K-023/172L	3/4	6	12	2.30	4.6	3.20	2.30	2.30	4.83	3.45	2.30
8-292K-032/156L	1	8	16	3.20	6.4	4.50	3.20	3.20	6.70	4.80	3.20
8-292K-045/208L	1 1/4	12	24	4.50	9.0	6.30	4.50	4.50	9.40	6.70	4.50

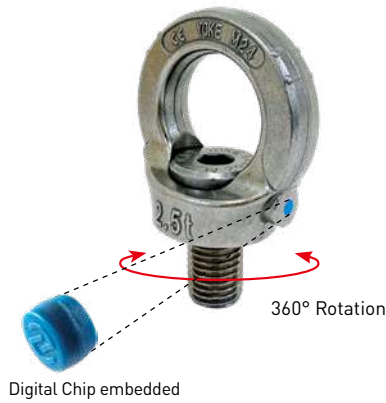
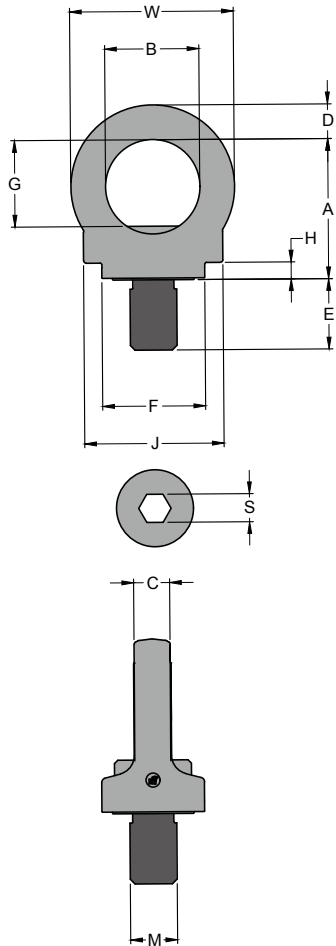

Digital Chip embedded with Certificate for serial Traceability

- Rotates through 360° adjustable in the direction of the load.
- Manufactured from stainless steel.
- Tested in accordance with EN1677-1.
- Individual forged parts and cap screw are traceable to Test Certification.
- Bolts are Metric thread.
- Proof tested to 2.5 times the WLL.
- Fatigue rated to 20,000 cycles at 1.5 times the WLL.
- All YOKE Lifting points meet or exceed all the requirements of ASME B30.26.
- Quick and simple assembly, just a tapped hole is required.
- Used in different applications such as chemical oil coal industries, food processing, clean room and precision instrument.

- » Mexico Patent: 3423
- » Japan Patent: 3192016
- » China Patent: ZL 2012 1 0131962.1/
ZL 2014 2 0228663.4
- » Taiwan Patent: I468602
- » United States Patent: 10607128
- » UK Patent: 3627396
- » German Patent: 602018032891.2
- » Italy Patent: 3627396
- » Japan Patent: 3219858

Digital Stainless Steel Eye Point Metric Thread (8-S291)

Item No.	Working Load Limit tonnes	Thread version			Dimensions										Torque in		N.W. kg
		M	E	Pitch DIN13	A	B	C	D	F	G	H	J	S	W	Nm		
8-S291-005	0.5	M 12	18	1.75	45	30	10	11	33	29	5	44	8	52	10	0.2	
8-S291-010	1.0	M 16	24	2.00	52	35	14	13	35	33	5	51	10	61	30	0.3	
8-S291-020	2.0	M 20	30	2.50	60	40	16	15	44	37	7	60	12	70	70	0.6	
8-S291-025	2.5	M 24	36	3.00	72	49	19	18	52	46	10	72	14	84	150	1.0	

* Design Factor 4:1





Kind of attachment											
Number of legs	Load direction	1	2	1	2	2	2	2	3-4	3-4	3-4
Item No.	Thread	0°	0°	90°	90°	0-45°	45°- 60°	unsymm.	0 - 45°	45°- 60°	unsymm.
		WLL(t)									
8-S291-005	M12	1.2	2.4	0.5	1	0.7	0.5	0.5	1.00	0.75	0.5
8-S291-010	M16	2.4	4.8	1.0	2	1.4	1.0	1.0	2.10	1.50	1.0
8-S291-020	M20	3.6	7.2	2.0	4	2.8	2.0	2.0	4.20	3.00	2.0
8-S291-025	M24	5.2	10.4	2.5	5	3.5	2.5	2.5	5.25	3.75	2.5

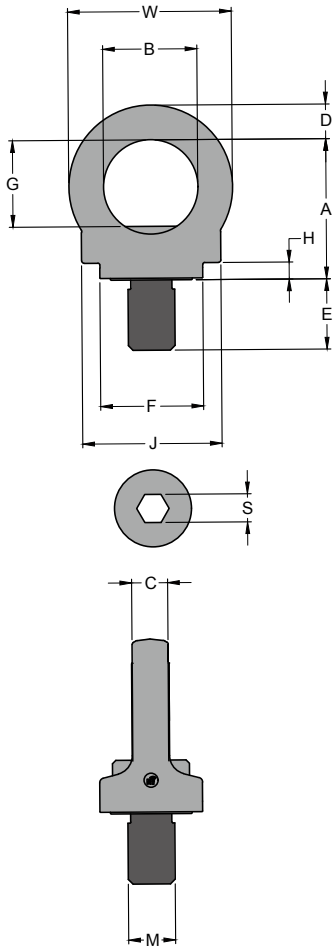

Digital Chip embedded with Certificate for serial Traceability

- Rotates through 360° adjustable in the direction of the load.
- Manufactured from stainless steel.
- Tested in accordance with EN1677-1.
- Individual forged parts and cap screw are traceable to Test Certification.
- Bolts are UNC thread.
- Proof tested to 2.5 times the WLL.
- Fatigue rated to 20,000 cycles at 1.5 times the WLL.
- All YOKE Lifting points meet or exceed all the requirements of ASME B30.26.
- Quick and simple assembly, just a tapped hole is required.
- Used in different applications such as chemical oil coal industries, food processing, clean room and precision instrument.

- » Mexico Patent: 3423
- » Japan Patent: 3192016
- » China Patent: ZL 2012 1 0131962.1/
ZL 2014 2 0228663.4
- » Taiwan Patent: I468602
- » United States Patent: 10607128
- » UK Patent: 3627396
- » German Patent: 602018032891.2
- » Italy Patent: 3627396
- » Japan Patent: 3219858

Digital Stainless Steel Eye Point

UNC Thread (8-S292)

Item No.	Working Load Limit	Thread version			Dimensions										Torque		N.W.
		M	E	TPI	A	B	C	D	F	G	H	J	S	W	in	lbs	
	tonnes	inch	inch		inch										Nm		
8-S292-005	0.5	1/2	0.75	13UNC	1.77	1.18	0.39	0.43	1.30	1.14	0.2	1.73	0.31	0.31	10	0.4	
8-S292-010	1.0	5/8	0.94	11UNC	2.05	1.38	0.55	0.51	1.38	1.30	0.2	2.01	0.39	0.39	30	0.7	
8-S292-020	2.0	3/4	1.40	10UNC	2.36	1.57	0.63	0.59	1.73	1.46	0.28	2.36	0.47	0.47	70	1.3	
8-S292-025	2.5	1	1.52	8UNC	2.83	1.93	0.75	0.71	2.05	1.81	0.39	2.83	0.55	0.55	150	2.2	

* Design Factor 4:1





Kind of attachment											
Number of legs	Thread	1	2	1	2	2	2	2	3-4	3-4	3-4
Load direction	Thread	0°	0°	90°	90°	0-45°	45°- 60°	unsymm.	0 - 45°	45°- 60°	unsymm.
Item No.	Inch	WLL(t)									
8-S292-005	1/2	1.2	2.4	0.5	1	0.7	0.5	0.5	1.00	0.75	0.5
8-S292-010	5/8	2.4	4.8	1.0	2	1.4	1.0	1.0	2.10	1.50	1.0
8-S292-020	3/4	3.6	7.2	2.0	4	2.8	2.0	2.0	4.20	3.00	2.0
8-S292-025	1	5.2	10.4	2.5	5	3.5	2.5	2.5	5.25	3.75	2.5

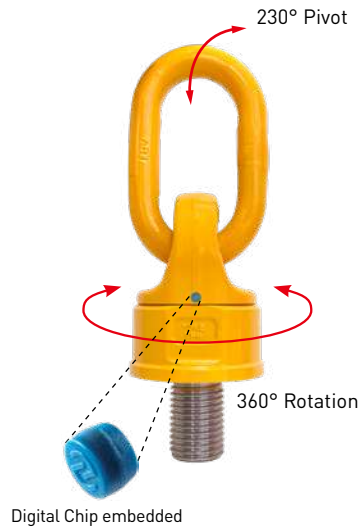
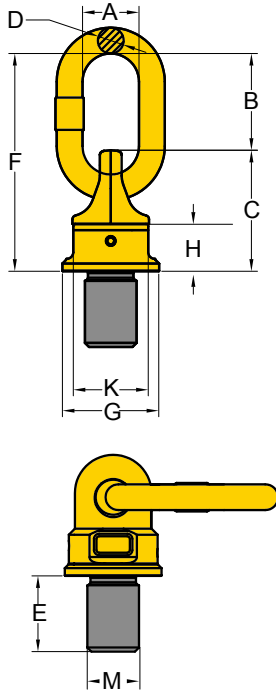

Digital Chip embedded with Certificate for serial Traceability

- Pivots to 230°, rotates through 360° due to its unique ball bearing design.
- Manufactured from forged alloy steel, quenched and tempered.
- Tested in accordance with EN1677-4.
- Certified by DGVV GS-0A-15-04.
- Load rated parts are 100% magnaflux crack detected.
- Individual forged parts and batch code links to Test Certificate sheet.
- Bolts are Metric thread.
- Proof tested to 2.5 times the WLL.
- Fatigue rated to 20,000 cycles at 1.5 times the WLL.
- All YOKE Lifting points meet or exceed all the requirements of ASME B30.26.
- Easy to attach or dismantle due to the forged hexagon shaped body of the Swivel Point.
- Capable of rotating under load. Do not turn continuously in 90 degree direction at full load.

- » United States Patent: 10607128
- » UK Patent: 3627396
- » German Patent: 602018032891.2
- » Italy Patent: 3627396
- » Japan Patent: 3219858

Digital Swivel Point Metric Thread (8-271)

Item No.	Working Load Limit tonnes	Thread version			Dimensions (mm)								Torque in		N.W. kg
		M	E	Pitch	G	C	K	H	F	D	B	A	Nm	kg	
		mm	mm	DIN13	mm	mm	mm	mm	mm	mm	mm	mm			
8-271-003	0.4	M 8	12	1.25	35	40	30	16	72	8	32	29	10	0.2	
8-271-004	0.6	M 10	15	1.50	35	40	30	16	72	8	32	29	10	0.2	
8-271-006	0.7	M 12	18	1.75	40	45	36	18	95	10	50	35	10	0.3	
8-271-013	1.5	M 16	24	2.00	46	54	41	22	104	13	50	36	30	0.5	
8-271-020	2.5	M 20	30	2.50	62	68	55	29	122	13	54	36	70	1.0	
8-271-035	4.0	M 24	36	3.00	78	88	70	36	154	19	66	41	150	2.2	
8-271-060	6.0	M 30	45	3.50	90	120	80	48	206	22	86	50	350	4.5	
8-271-067	6.7	M 30	45	3.50	90	120	80	48	206	22	86	50	350	4.5	
8-271-080	10.0	M 36	54	4.00	90	120	80	48	206	22	86	50	410	4.6	
8-271-120	13.0	M 42	63	4.50	98	122	84	50	235	25	110	67	550	5.5	
8-271-130	14.0	M 48	72	5.00	98	122	84	50	235	25	110	67	550	6.1	
8-271-140	20.0	M 52	78	5.00	120	150	94	60	270	32	120	72	750	10.5	
8-271-160	20.0	M 56	84	5.50	120	150	94	60	270	32	120	72	800	10.7	
8-271-161	20.0	M 64	96	6.00	120	150	94	60	270	32	120	72	800	11.6	
8-271-310	40.0	M 72	108	6.00	170	210	145	83	340	45	130	90	1200	30.6	
8-271-350	40.0	M 80	120	6.00	170	210	145	83	340	45	130	90	1500	31.6	
8-271-400	40.0	M 90	135	6.00	170	210	145	83	340	45	130	90	2000	33.9	

* Design Factor 4:1





Kind of attachment											
Number of legs		1	2	1	2	2	2	2	3-4	3-4	3-4
Load direction		0°	0°	90°	90°	0-45°	45°- 60°	unsymm.	0 - 45°	45°- 60°	unsymm.
Item No.	Thread	WLL(t)									
8-271-003	M 8	0.6	1.2	0.4	0.8	0.56	0.4	0.4	0.84	0.60	0.4
8-271-004	M10	0.9	1.8	0.6	1.2	0.84	0.6	0.6	1.26	0.90	0.6
8-271-006	M12	1.2	2.4	0.7	1.4	0.98	0.7	0.7	1.47	1.05	0.7
8-271-013	M16	2.6	5.2	1.5	3.0	2.10	1.5	1.5	3.15	2.25	1.5
8-271-020	M20	4.0	8.0	2.5	5.0	3.50	2.5	2.5	5.25	3.75	2.5
8-271-035	M24	7.0	14.0	4.0	8.0	5.60	4.0	4.0	8.40	6.00	4.0
8-271-060	M30	10.0	20.0	6.0	12.0	8.40	6.0	6.0	12.60	9.00	6.0
8-271-067	M30	12.0	24.0	6.7	13.4	9.40	6.7	6.7	14.10	10.00	6.7
8-271-080	M36	15.0	30.0	10.0	20.0	14.00	10.0	10.0	21.00	15.00	10.0
8-271-120	M42	17.0	34.0	13.0	26.0	18.20	13.0	13.0	27.30	19.50	13.0
8-271-130	M48	18.0	36.0	14.0	28.0	19.60	14.0	14.0	29.40	21.00	14.0
8-271-140	M52	25.0	50.0	20.0	40.0	28.00	20.0	20.0	42.00	30.00	20.0
8-271-160	M56	28.0	56.0	20.0	40.0	28.00	20.0	20.0	42.00	30.00	20.0
8-271-161	M64	28.0	56.0	20.0	40.0	28.00	20.0	20.0	42.00	30.00	20.0
8-271-310	M72	50.0	100.0	40.0	80.0	56.00	40.0	40.0	84.00	60.00	40.0
8-271-350	M80	50.0	100.0	40.0	80.0	56.00	40.0	40.0	84.00	60.00	40.0
8-271-400	M90	50.0	100.0	40.0	80.0	56.00	40.0	40.0	84.00	60.00	40.0

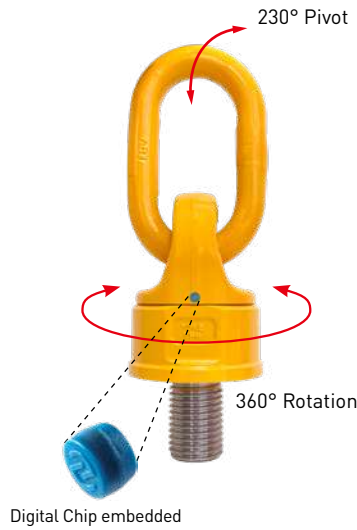
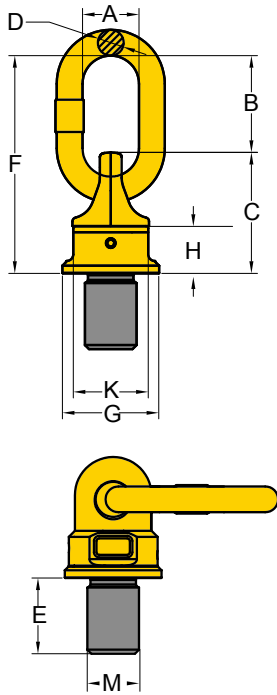

- Pivots to 230°, rotates through 360° due to its unique ball bearing design.
- Manufactured from forged alloy steel, quenched and tempered.
- Tested in accordance with EN1677-4.
- Load rated parts are 100% magnaflux crack detected.
- Individual forged parts and batch code links to Test Certificate sheet.
- Bolts are UNC thread.
- Proof tested to 2.5 times the WLL.
- Fatigue rated to 20,000 cycles at 1.5 times the WLL.
- All YOKE Lifting points meet or exceed all the requirements of ASME B30.26.
- Easy to attach or dismantle due to the forged hexagon shaped body of the Swivel Point.
- Capable of rotating under load. Do not turn continuously in 90 degree direction at full load.



Digital Chip embedded with Certificate for serial Traceability

- » United States Patent: 10607128
- » UK Patent: 3627396
- » German Patent: 602018032891.2
- » Italy Patent: 3627396
- » Japan Patent: 3219858

Digital Swivel Point

UNC Thread (8-272)

Item No.	Working Load Limit	Thread version			Dimensions							Torque		N.W.		
		M	E	TPI	G	C	K	H	F	D	B	A	in			
	tonnes	inch	inch					inch							Nm	lbs
8-272-006	0.7	1/2	0.75	13UNC	1.57	1.77	1.42	0.71	3.74	0.39	1.97	1.38	15	0.7		
8-272-013	1.5	5/8	0.94	11UNC	1.81	2.13	1.61	0.87	4.09	0.51	1.97	1.42	45	1.2		
8-272-018	2.0	3/4	1.13	10UNC	1.81	2.68	1.61	0.87	4.09	0.51	1.97	1.42	45	1.2		
8-272-020	2.5	7/8	1.31	9UNC	2.44	2.68	2.17	1.14	4.80	0.51	2.13	1.42	100	2.2		
8-272-035	4.0	1	1.50	8UNC	3.07	3.46	2.76	1.42	6.06	0.75	2.60	1.61	190	4.8		
8-272-060	6.0	1 1/4	1.88	7UNC	3.54	4.72	3.15	1.89	8.11	0.87	3.39	1.97	270	9.9		
8-272-080	10.0	1 1/2	2.25	6UNC	3.54	4.72	3.15	1.89	8.11	0.87	3.39	1.97	270	10.0		
8-272-120	13.0	1 3/4	2.63	5UNC	3.86	4.80	3.31	1.97	9.25	0.98	4.33	2.64	350	12.1		
8-272-130	14.0	2	3.00	4.5UNC	3.86	4.80	3.31	1.97	9.25	0.98	4.33	2.64	350	13.5		
8-272-140	20.0	2 1/4	3.38	4.5UNC	4.72	5.91	3.70	2.36	10.63	1.26	4.72	2.83	350	23.1		
8-272-160	20.0	2 1/2	3.75	4UNC	4.72	5.91	3.70	2.36	10.63	1.26	4.72	2.83	350	23.5		

* Design Factor 4:1

* Please refer to 8-252 table for specification \geq 3-4UNC.



Kind of attachment																
	Number of legs	1	2	1	2	2	2	2	3-4	3-4	3-4	3-4	3-4	3-4	3-4	3-4
Load direction Thread	0°	0°	90°	90°	0-45°	45°- 60°	unsymm.	0 - 45°	45°- 60°	unsymm.						
Item No.	Inch	WLL(t)														
8-272-006	1/2	1.2	2.4	0.7	1.4	0.98	0.7	0.7	1.47	1.05	0.7					
8-272-013	5/8	2.6	5.2	1.5	3.0	2.10	1.5	1.5	3.15	2.25	1.5					
8-272-018	3/4	3.6	7.2	2.0	4.0	2.80	2.0	2.0	4.20	3.00	2.0					
8-272-020	7/8	4.0	8.0	2.5	5.0	3.50	2.5	2.5	5.25	3.75	2.5					
8-272-035	1	7.0	14.0	4.0	8.0	5.60	4.0	4.0	8.40	6.00	4.0					
8-272-060	1 1/4	10.0	20.0	6.0	12.0	8.40	6.0	6.0	12.60	9.00	6.0					
8-272-080	1 1/2	15.0	30.0	10.0	20.0	14.00	10.0	10.0	21.00	15.00	10.0					
8-272-120	1 3/4	17.0	34.0	13.0	26.0	18.20	13.0	13.0	27.30	19.50	13.0					
8-272-130	2	18.0	36.0	14.0	28.0	19.60	14.0	14.0	29.40	21.00	14.0					
8-272-140	2 1/4	25.0	50.0	20.0	40.0	28.00	20.0	20.0	42.00	30.00	20.0					
8-272-160	2 1/2	28.0	56.0	20.0	40.0	28.00	20.0	20.0	42.00	30.00	20.0					

* Please refer to 8-252 table for specification \geq 3-4UNC.

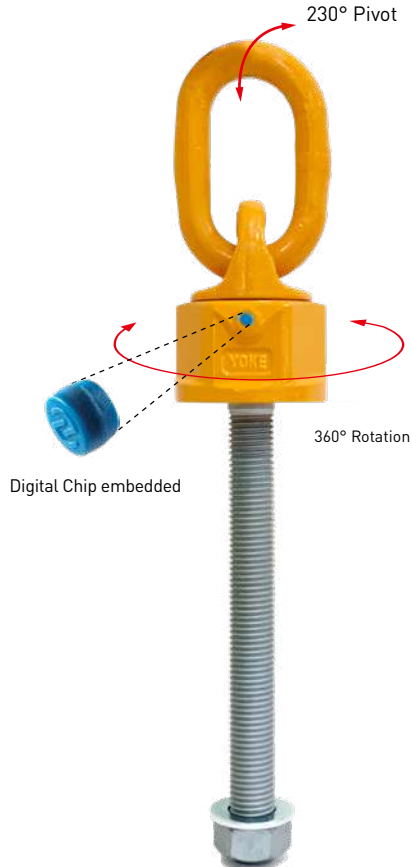
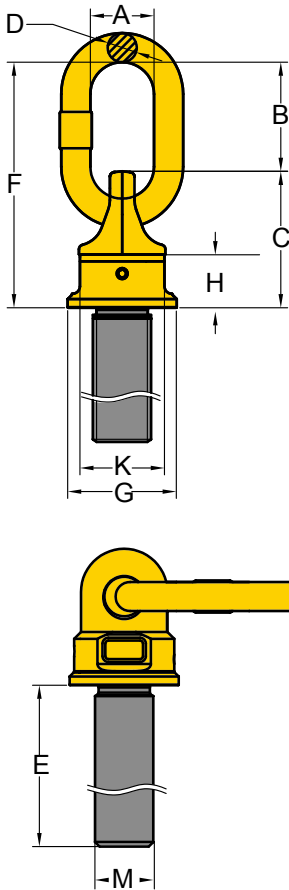

- Pivots to 230°, rotates through 360° due to its unique ball bearing design.
- Manufactured from forged alloy steel, quenched and tempered.
- Tested in accordance with EN1677-4.
- Load rated parts are 100% magnaflux crack detected.
- Individual forged parts and batch code links to Test Certificate sheet.
- Bolts are Metric thread.
- Proof tested to 2.5 times the WLL.
- Fatigue rated to 20,000 cycles at 1.5 times the WLL.
- All YOKE Lifting points meet or exceed all the requirements of ASME B30.26.
- Easy to attach or dismantle due to the forged hexagon shaped body of the Swivel Point.
- Capable of rotating under load. Do not turn continuously in 90 degree direction at full load.

- » United States Patent: 10607128
- » UK Patent: 3627396
- » German Patent: 602018032891.2
- » Italy Patent: 3627396
- » Japan Patent: 3219858

Digital Swivel Point, Long Bolt Metric Thread (8-273)

NEW

Digital Chip embedded
with Certificate
for serial Traceability

Item No.	Working Load Limit	Thread version			Dimensions (mm)								Torque in		N.W.
		M	E	Pitch	G	C	K	H	F	D	B	A	Nm	kg	
	tonnes	mm	mm	DIN13											
8-273-003/108L	0.30	M 8	102	1.25	35	47.5	30	23.5	79.5	8	32	29	10 - 40	0.5	
8-273-004/128L	0.45	M 10	122	1.50	35	47.5	30	23.5	79.5	8	32	29	10 - 40	0.5	
8-273-006/145L	0.60	M 12	140	1.75	40	55.0	36	28.0	105.0	10	50	35	15 - 40	0.8	
8-273-013/186L	1.30	M 16	180	2.00	46	66.0	41	34.0	116.0	13	50	36	45 - 130	1.2	
8-273-020/235L	2.00	M 20	223	2.50	62	83.0	55	44.0	137.0	13	54	36	100 - 170	2.0	
8-273-035/267L	3.50	M 24	257	3.00	78	105.0	70	53.0	171.0	19	66	41	190 - 280	3.5	
8-273-050/346L	5.00	M 30	330	3.50	90	141.0	80	69.0	227.0	22	86	50	270 - 600	6.8	

* Design Factor 4:1





Kind of attachment											
Number of legs	Load direction	1	2	1	2	2	2	2	3-4	3-4	3-4
		0°	0°	90°	90°	0-45°	45°- 60°	unsymm.	0 - 45°	45°- 60°	unsymm.
Item No.	Thread	WLL(t)									
8-273-003/108L	M 8	0.6	1.2	0.30	0.6	0.42	0.30	0.30	0.63	0.45	0.30
8-273-004/128L	M10	0.9	1.8	0.45	0.9	0.63	0.45	0.45	0.95	0.68	0.45
8-273-006/145L	M12	1.2	2.4	0.60	1.2	0.84	0.60	0.60	1.26	0.90	0.60
8-273-013/186L	M16	2.6	5.2	1.30	2.6	1.82	1.30	1.30	2.73	1.95	1.30
8-273-020/235L	M20	4.0	8.0	2.00	4.0	2.80	2.00	2.00	4.20	3.00	2.00
8-273-035/267L	M24	7.0	14.0	3.50	7.0	4.90	3.50	3.50	7.35	5.25	3.50
8-273-050/346L	M30	10.0	20.0	5.00	10.0	7.00	5.00	5.00	10.50	7.50	5.00

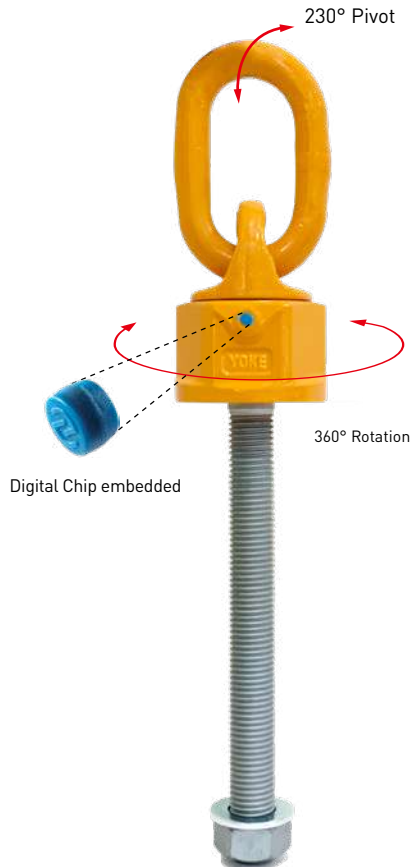
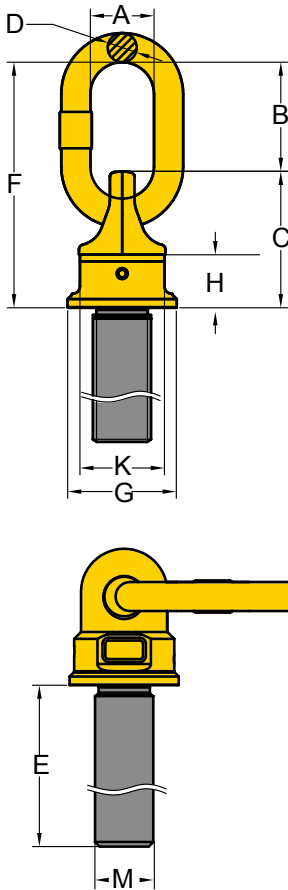

- Pivots to 230°, rotates through 360° due to its unique ball bearing design.
- Manufactured from forged alloy steel, quenched and tempered.
- Tested in accordance with EN1677-4.
- Load rated parts are 100% magnaflux crack detected.
- Individual forged parts and batch code links to Test Certificate sheet.
- Bolts are UNC thread.
- Proof tested to 2.5 times the WLL.
- Fatigue rated to 20,000 cycles at 1.5 times the WLL.
- All YOKE Lifting points meet or exceed all the requirements of ASME B30.26.
- Easy to attach or dismantle due to the forged hexagon shaped body of the Swivel Point.
- Capable of rotating under load. Do not turn continuously in 90 degree direction at full load.

- » United States Patent: 10607128
- » UK Patent: 3627396
- » German Patent: 602018032891.2
- » Italy Patent: 3627396
- » Japan Patent: 3219858

Digital Swivel Point, Long Bolt

UNC Thread (8-274)

NEW

Digital Chip embedded with Certificate for serial Traceability

Item No.	Working Load Limit	Thread version			Dimensions							Torque		N.W.		
		M	E	TPI	G	C	K	H	F	D	B	A	in		lbs	
	tonnes	inch	inch					inch							Nm	
8-274-006/154L	0.6	1/2	5.87	13UNC	1.57	2.17	1.42	1.10	4.13	0.39	1.97	1.38	15 - 40	0.9		
8-274-013/186L	1.3	5/8	7.09	11UNC	1.81	2.60	1.61	1.34	4.57	0.51	1.97	1.42	45 - 130	1.7		
8-274-018/234L	2.0	3/4	8.74	10UNC	2.44	3.25	2.17	1.71	5.37	0.51	2.13	1.42	45 - 130	2.3		
8-274-035/256L	3.5	1	9.69	8UNC	3.07	4.13	2.76	2.09	6.73	0.75	2.60	1.61	190 - 280	6.5		
8-274-050/247L	5.0	1 1/4	13.03	7UNC	3.54	5.55	3.15	2.72	8.94	0.87	3.39	1.97	270 - 600	13.4		

* Design Factor 4:1

* Please refer to 8-252 table for specification \geq 3-4UNC.

* Design Factor 4:1





Kind of attachment											
Number of legs	1	2	1	2	2	2	2	3-4	3-4	3-4	
Load direction	0°	0°	90°	90°	0-45°	45°- 60°	unsymm.	0 - 45°	45°- 60°	unsymm.	
Item No.	Thread	WLL(t)									
8-274-006/154L	1/2	1.2	2.4	0.6	1.2	0.84	0.6	0.6	1.26	0.90	0.6
8-274-013/186L	5/8	2.6	5.2	1.3	2.6	1.82	1.3	1.3	2.73	1.95	1.3
8-274-018/234L	3/4	3.6	7.2	2.0	4.0	2.80	2.0	2.0	4.20	3.00	2.0
8-274-035/256L	1	7.0	14.0	3.5	7.0	4.90	3.5	3.5	7.35	5.25	3.5
8-274-050/247L	1 1/4	10.0	20.0	5.0	10.0	7.00	5.0	5.0	10.50	7.50	5.0

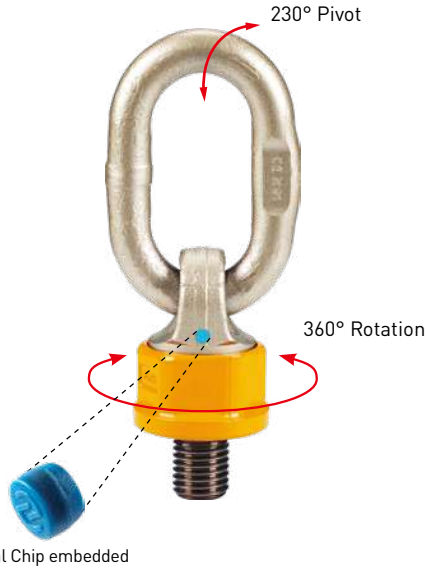
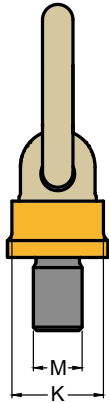
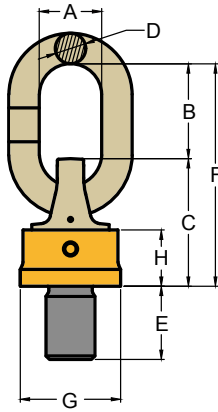

Digital Chip embedded with Certificate for serial Traceability

- Pivots to 230°, rotates through 360° due to its unique ball bearing design.
- Manufactured from forged alloy steel, quenched and tempered.
- Tested in accordance with EN1677-4.
- All YOKE Lifting points meet or Certified by DGUV GS-0A-15-04.
- Load rated parts are 100% magnaflux crack detected.
- Individual forged parts and batch code links to Test Certificate sheet.
- Bolts are Metric thread.
- Proof tested to 2.5 times the WLL.
- Fatigue rated to 20,000 cycles at 1.5 times the WLL.
- All YOKE Lifting points meet or exceed all the requirements of ASME B30.26.
- Easy to attach or dismantle due to the forged hexagon shaped body of the Super Point
- Capable of rotating under load. Do not turn continuously in 90 degree direction at full load.
- With the new WLL tables you can find the right Super Point attachment for your application and by the yellow marking on both sides you can measure disposal stage of the Super Point.

- » United States Patent: 10607128
- » UK Patent: 3627396
- » German Patent: 602018032891.2
- » Italy Patent: 3627396
- » Japan Patent: 3219858

Digital Super Point

Metric Thread (8-251)

Digital Super Point

UNC Thread (8-252)

* Design Factor 4:1





Kind of attachment											
Number of legs	Thread	1	2	1	2	2	2	2	3-4	3-4	3-4
Load direction		0°	0°	90°	90°	0-45°	45°- 60°	unsymm.	0 - 45°	45°- 60°	unsymm.
Item No.	Thread	WLL(t)									
8-251-004	M8	0.6	1.2	0.3	0.6	0.40	0.3	0.3	0.60	0.45	0.3
	M10	1.0	2.0	0.5	1.0	0.70	0.5	0.5	1.00	0.75	0.5
8-251-0 07	M12	1.4	2.8	0.7	1.4	1.00	0.7	0.7	1.40	1.00	0.7
	M14	2.0	4.0	1.0	2.0	1.40	1.0	1.0	2.12	1.50	1.0
8-251-014	M16	2.8	5.6	1.4	2.8	2.00	1.4	1.4	3.00	2.12	1.4
	M20	3.4	6.8	1.7	3.4	2.40	1.7	1.7	3.55	2.50	1.7
	M24	3.4	6.8	1.7	3.4	2.40	1.7	1.7	3.55	2.50	1.7
8-251-025	M20	5.0	10.0	2.5	5.0	3.55	2.5	2.5	5.30	3.75	2.5
8-251-040	M24	8.0	16.0	4.0	8.0	5.60	4.0	4.0	8.50	6.00	4.0
	M30	8.0	16.0	4.0	8.0	5.60	4.0	4.0	8.50	6.00	4.0
8-251-067	M30	12.0	24.0	6.7	13.4	9.50	6.7	6.7	14.00	10.00	6.7
8-251-080	M30	12.0	24.0	8.0	16.0	11.20	8.0	8.0	16.00	12.00	8.0
8-251-100	M36	15.0	30.0	10.0	20.0	14.00	10.0	10.0	21.20	15.00	10.0
8-251-125	M42	15.0	30.0	12.5	25.0	17.00	12.5	12.5	25.00	18.00	12.5
	M45	15.0	30.0	12.5	25.0	17.00	12.5	12.5	25.00	18.00	12.5
	M48	15.0	30.0	12.5	25.0	17.00	12.5	12.5	25.00	18.00	12.5
8-251-170	M42	20.0	40.0	13.0	26.0	18.00	13.0	13.0	27.00	19.00	13.0
	M45	25.0	50.0	17.0	34.0	23.50	17.0	17.0	35.00	25.00	17.0
	M48	25.0	50.0	17.0	34.0	23.50	17.0	17.0	35.00	25.00	17.0
	M52	25.0	50.0	17.0	34.0	23.50	17.0	17.0	35.00	25.00	17.0
8-251-200	M56	25.0	50.0	18.0	36.0	25.00	18.0	18.0	37.50	26.50	18.0
	M64	25.0	50.0	20.0	40.0	28.00	20.0	20.0	42.50	30.00	20.0
8-251-280	M64	32.5	65.0	28.0	56.0	39.00	28.0	28.0	58.00	42.00	28.0
	M72	32.5	65.0	28.0	56.0	39.00	28.0	28.0	58.00	42.00	28.0
8-251-350	M80	40.0	80.0	35.0	70.0	49.00	35.0	35.0	74.00	52.50	35.0
	M80	40.0	80.0	35.0	70.0	49.00	35.0	35.0	74.00	52.50	35.0
	M90	40.0	80.0	35.0	70.0	49.00	35.0	35.0	74.00	52.50	35.0
8-251-400	M72	50.0	100.0	40.0	80.0	56.00	40.0	40.0	84.00	60.00	40.0
	M80	50.0	100.0	40.0	80.0	56.00	40.0	40.0	84.00	60.00	40.0
	M90	50.0	100.0	40.0	80.0	56.00	40.0	40.0	84.00	60.00	40.0
	M100	50.0	100.0	40.0	80.0	56.00	40.0	40.0	84.00	60.00	40.0

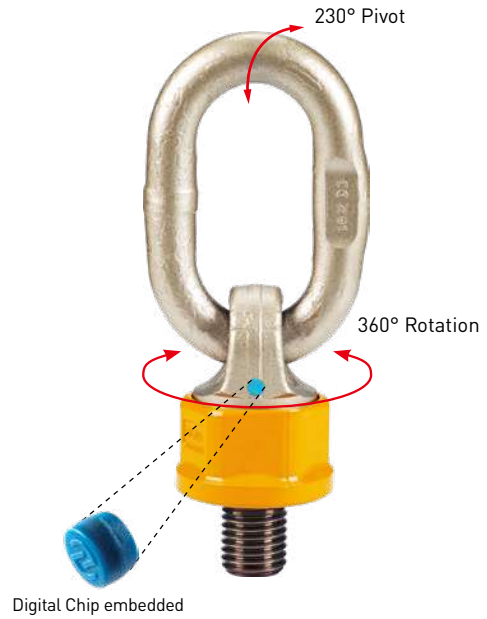
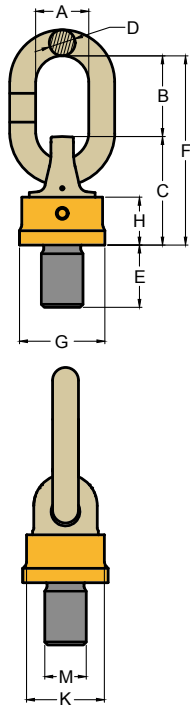

Digital Chip embedded with Certificate for serial Traceability

Digital Super Point

Metric Thread (8-251)

Item No.	Working Load Limit	Thread version			Dimensions								Torque in		N.W.
		M	E	Pitch	G	C	K	H	F	D	B	A	Nm	kg	
	tonnes	mm	mm	DIN13				mm							
8-251-004-01	0.3	M8	12	1.25	36.5	48	34	20.5	101	13	53	35	10 - 40	0.3	
8-251-007-02	0.7	M12	18	1.75	36.5	48	34	20.5	101	13	53	35	15 - 40	0.4	
8-251-014-02	1.4	M16	24	2.00	36.5	48	34	20.5	101	13	53	35	45 - 130	0.5	
8-251-014-04	1.7	M20	30	2.50	36.5	48	34	20.5	101	13	53	35	75 - 130	0.5	
8-251-025-01	2.5	M20	30	2.50	52.0	68	46	28.0	127	16	59	35	100 - 170	1.0	
8-251-040-02	4.0	M24	36	3.00	57.0	75	50	34.5	148	19	73	40	190 - 280	1.5	
8-251-067-02	6.7	M30	45	3.50	70.0	95	65	41.0	163	20	68	40	230 - 400	2.4	
8-251-080-02	8.0	M30	45	3.50	81.0	106	75	48.0	201	22	95	50	270 - 600	3.7	
8-251-100-02	10.0	M36	54	4.00	81.0	106	75	48.0	201	22	95	50	270 - 600	3.9	
8-251-125-03	12.5	M42	63	4.50	81.0	106	75	48.0	201	22	95	50	270 - 700	4.0	
8-251-125-05	12.5	M48	72	5.00	81.0	106	75	48.0	201	22	95	50	270 - 700	4.4	
8-251-170-04	17.0	M48	72	5.00	104.0	127	95	58.0	256	32	129	70	350 - 800	7.7	

* Design Factor 4:1

for Size Quick View

Item No.	Working Load Limit	Thread version			Dimensions								Torque in		N.W.	
		y	M	E	Pitch	G	C	K	H	F	D	B	A	Nm		kg
		tonnes	inch	mm	DIN13	mm										
8-251-004-01	0.3	M8	12	1.25	36.5	48	34	20.5	101	13	53	35	10 - 40	0.3		
8-251-007-01	0.5	M10	18	1.50	36.5	48	34	20.5	101	13	53	35	10 - 40	0.4		
8-251-007-02	0.7	M12	18	1.75	36.5	48	34	20.5	101	13	53	35	15 - 40	0.4		
8-251-007-03	0.7	M12	25	1.75	36.5	48	34	20.5	101	13	53	35	15 - 40	0.4		
8-251-007-04	1.0	M14	20	2.00	36.5	48	34	20.5	101	13	53	35	30 - 40	0.4		
8-251-014-01	1.4	M16	20	2.00	36.5	48	34	20.5	101	13	53	35	45 - 130	0.44		
8-251-014-02	1.4	M16	24	2.00	36.5	48	34	20.5	101	13	53	35	45 - 130	0.5		
8-251-014-03	1.4	M16	30	2.00	36.5	48	34	20.5	101	13	53	35	45 - 130	0.5		
8-251-014-04	1.7	M20	30	2.50	36.5	48	34	20.5	101	13	53	35	75 - 130	0.5		
8-251-014-05	1.7	M24	30	3.00	36.5	48	34	20.5	101	13	53	35	90 - 130	0.5		
8-251-025-01	2.5	M20	30	2.50	52	68	46	28	127	16	59	35	100 - 170	1.0		
8-251-025-02	2.5	M20	40	2.50	52	68	46	28	127	16	59	35	100 - 170	1.0		
8-251-025-03	2.5	M20	50	2.50	52	68	46	28	127	16	59	35	100 - 170	1.1		
8-251-025-04	2.5	M20	70	2.50	52	68	46	28	127	16	59	35	100 - 170	1.1		
8-251-040-01	4.0	M24	30	3.00	57	75	50	34.5	148	19	73	40	190 - 280	1.5		
8-251-040-02	4.0	M24	36	3.00	57	75	50	34.5	148	19	73	40	190 - 280	1.5		
8-251-040-03	4.0	M24	45	3.00	57	75	50	34.5	148	19	73	40	190 - 280	1.5		
8-251-040-04	4.0	M24	50	3.00	57	75	50	34.5	148	19	73	40	190 - 280	1.5		
8-251-040-05	4.0	M30	35	3.50	57	75	50	34.5	148	19	73	40	190 - 280	1.5		
8-251-067-01	6.7	M30	35	3.50	70	95	65	41	163	20	68	40	230 - 400	2.4		
8-251-067-02	6.7	M30	45	3.50	70	95	65	41	163	20	68	40	230 - 400	2.4		
8-251-067-03	6.7	M30	50	3.50	70	95	65	41	163	20	68	40	230 - 400	2.5		
8-251-067-04	6.7	M30	60	3.50	70	95	65	41	163	20	68	40	230 - 400	2.5		
8-251-080-01	8.0	M30	35	3.50	81	106	75	48	201	22	95	50	270 - 600	3.6		
8-251-080-02	8.0	M30	45	3.50	81	106	75	48	201	22	95	50	270 - 600	3.7		
8-251-100-01	10.0	M36	50	4.00	81	106	75	48	201	22	95	50	270 - 600	3.8		
8-251-100-02	10.0	M36	54	4.00	81	106	75	48	201	22	95	50	270 - 600	3.9		
8-251-125-01	12.5	M42	50	4.50	81	106	75	48	201	22	95	50	270 - 700	3.9		
8-251-125-02	12.5	M42	60	4.50	81	106	75	48	201	22	95	50	270 - 700	4.0		
8-251-125-03	12.5	M42	63	4.50	81	106	75	48	201	22	95	50	270 - 700	4.0		
8-251-125-04	12.5	M45	60	4.50	81	106	75	48	201	22	95	50	270 - 700	4.1		
8-251-125-05	12.5	M48	72	5.00	81	106	75	48	201	22	95	50	270 - 700	4.4		
8-251-170-01	13.0	M42	60	4.50	104	127	95	58	256	32	129	70	350 - 800	7.4		
8-251-170-02	17.0	M45	60	4.50	104	127	95	58	256	32	129	70	350 - 800	7.5		
8-251-170-03	17.0	M48	60	5.00	104	127	95	58	256	32	129	70	350 - 800	7.6		
8-251-170-04	17.0	M48	72	5.00	104	127	95	58	256	32	129	70	350 - 800	7.7		
8-251-170-045	17.0	M52	78	5.00	104	127	95	58	256	32	129	70	350 - 800	7.9		
8-251-170-05	18.0	M56	78	5.50	104	127	95	58	256	32	129	70	350 - 900	8.1		
8-251-170-06	18.0	M56	84	5.50	104	127	95	58	256	32	129	70	350 - 900	8.1		
8-251-200-01	20.0	M64	96	6.00	104	127	95	58	256	32	129	70	350 - 900	8.9		
8-251-200-02	20.0	M64	110	6.00	104	127	95	58	256	32	129	70	350 - 900	9.3		
8-251-280-01	28.0	M64	96	6.00	129	174	115	78	305	36	131	80	500 - 1000	16.4		
8-251-280-02	28.0	M72	120	6.00	129	174	115	78	305	36	131	80	500 - 1200	17.7		
8-251-280-03	28.0	M80	150	6.00	129	174	115	78	305	36	131	80	500 - 1200	19.6		
8-251-350-005	35.0	M72	108	6.00	148	187	135	83	366	45	140	92	500 - 1400	24.8		
8-251-350-01	35.0	M80	120	6.00	148	187	135	83	366	45	140	92	500 - 1400	25.3		
8-251-350-02	35.0	M90	150	6.00	148	187	135	83	366	45	140	92	500 - 1500	27.8		
8-251-400-005	40.0	M72	108	6.00	170	210	145	83	340	45	130	92	500 - 1500	30.1		
8-251-400-01	40.0	M80	120	6.00	170	210	145	83	340	45	130	92	500 - 1500	31.9		
8-251-400-02	40.0	M90	115	6.00	170	210	145	83	340	45	130	92	500 - 1500	33.6		
8-251-400-025	40.0	M90	135	6.00	170	210	145	83	340	45	130	92	500 - 1500	33.9		
8-251-400-03	40.0	M90	150	6.00	170	210	145	83	340	45	130	92	500 - 1500	34.2		
8-251-400-04	40.0	M100	150	6.00	170	210	145	83	340	45	130	92	500 - 1700	35.2		

Copyright © 2023
YOKE Industrial Corp.
All Rights Reserved. * Design Factor 4:1



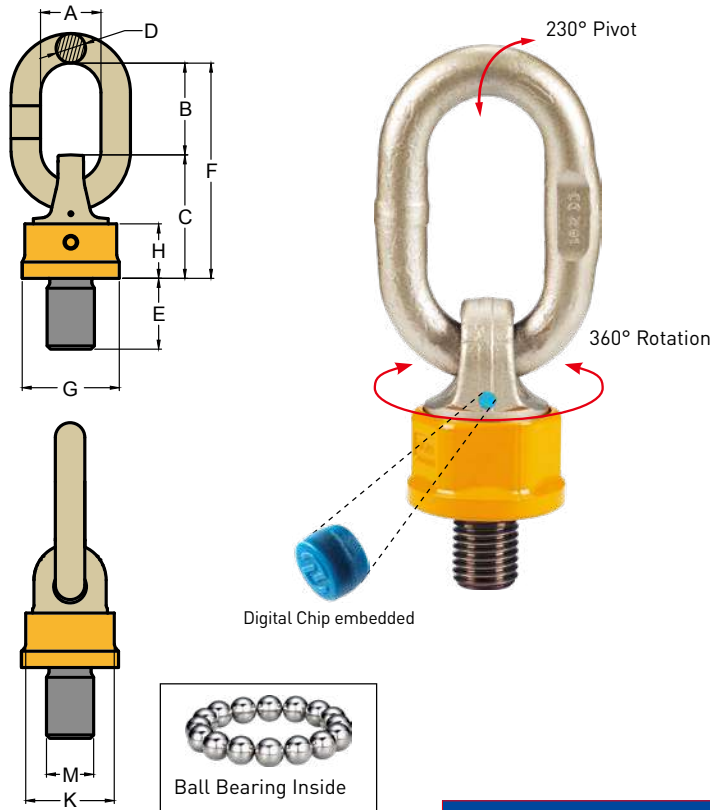

- Pivots to 230°, rotates through 360° due to its unique ball bearing design.
- Manufactured from forged alloy steel, quenched and tempered.
- Tested in accordance with EN1677-4.
- Load rated parts are 100% magnaflux crack detected.
- Individual forged parts and batch code links to Test Certificate sheet.
- Bolts are UNC thread.
- Proof tested to 2.5 times the WLL.
- Fatigue rated to 20,000 cycles at 1.5 times the WLL.
- All YOKE Lifting points meet or exceed all the requirements of ASME B30.26.
- Easy to attach or dismantle due to the forged hexagon shaped body of the Super Point.
- Capable of rotating under load. Do not turn continuously in 90 degree direction at full load.
- With the new WLL tables you can find the right Super Point attachment for your application and by the red marking on both sides you can measure disposal stage of the Super Point.

Digital Chip embedded with Certificate for serial Traceability

- » United States Patent: 10607128
- » UK Patent: 3627396
- » German Patent: 602018032891.2
- » Italy Patent: 3627396
- » Japan Patent: 3219858

Digital Super Point

UNC Thread (8-252)

Item No.	Working Load Limit	Thread version			Dimensions									Torque		N.W.
		M	E	TPI	G	C	K	H	F	D	B	A	in	lbs		
		tonnes	inch	inch	inch											
8-252-007-01	0.5	3/8	0.56	16UNC	1.44	1.89	1.34	0.81	3.98	0.51	2.09	1.38	10 - 40	1.0		
8-252-007-02	0.7	1/2	0.75	13UNC	1.44	1.89	1.34	0.81	3.98	0.51	2.09	1.38	15 - 40	1.0		
8-252-014-02	1.4	5/8	0.94	11UNC	1.44	1.89	1.34	0.81	3.98	0.51	2.09	1.38	45 - 130	1.0		
8-252-025-01	2.5	3/4	1.13	10UNC	2.05	2.68	1.81	1.10	5.00	0.63	2.32	1.38	100 - 170	2.1		
8-252-040-02	4.0	1	1.50	8UNC	2.24	2.95	1.97	1.36	5.83	0.75	2.87	1.57	190 - 280	3.3		
8-252-067-02	6.7	1 1/4	1.88	7UNC	2.76	3.74	2.56	1.61	6.42	0.79	2.68	1.57	230 - 400	5.3		
8-252-080-02	8.0	1 1/4	1.88	7UNC	3.19	4.17	2.95	1.89	7.91	0.87	3.74	1.97	270 - 600	8.1		
8-252-100-02	10.0	1 1/2	2.25	6UNC	3.19	4.17	2.95	1.89	7.91	0.87	3.74	1.97	270 - 600	8.3		
8-252-125-03	12.5	1 3/4	2.63	5UNC	3.19	4.17	2.95	1.89	7.91	0.87	3.74	1.97	270 - 700	8.8		
8-252-125-05	12.5	2	3.00	4.5UNC	3.19	4.17	2.95	1.89	7.91	0.87	3.74	1.97	270 - 700	9.7		
8-252-170-04	17.0	2	3.00	4.5UNC	4.09	5.00	3.74	2.28	10.08	1.26	5.08	2.76	350 - 800	16.7		
8-252-170-06	18.0	2 1/4	3.38	4.5UNC	4.09	5.00	3.74	2.28	10.08	1.26	5.08	2.76	350 - 900	17.8		
8-252-200-01	20.0	2 1/2	3.75	4UNC	4.09	5.00	3.74	2.28	10.08	1.26	5.08	2.76	350 - 900	19.6		
8-252-280-01	28.0	2 1/2	3.75	4UNC	5.08	6.85	4.53	3.07	12.01	1.42	5.16	3.15	500 - 1000	36.1		
8-252-350-01	35.0	3 1/2	5.25	4UNC	5.83	7.36	5.31	3.27	14.41	1.77	5.51	3.62	500 - 1400	55.7		

* Design Factor 4:1





Kind of attachment	1		2		1		2		2		2		3-4		3-4		3-4			
	0°	0°	90°	90°	0-45°	45°-60°	unsymm.	0-45°	45°-60°	unsymm.	0-45°	45°-60°	unsymm.	0-45°	45°-60°	unsymm.	0-45°	45°-60°	unsymm.	
Item No.	Inch	WLL(t)																		
8-252-007	3/8	1.0	2.0	0.5	1.0	0.70	0.5	0.5	1.0	0.75	0.5	1.0	0.75	0.5	1.0	0.75	0.5	1.0	0.75	0.5
	1/2	1.4	2.8	0.7	1.4	1.00	0.7	0.7	1.4	1.00	0.7	1.4	1.00	0.7	1.4	1.00	0.7	1.4	1.00	0.7
8-252-014	5/8	2.8	5.6	1.4	2.8	2.00	1.4	1.4	3.0	2.12	1.4	3.0	2.12	1.4	3.0	2.12	1.4	3.0	2.12	1.4
8-252-025	3/4	5.0	10.0	2.5	5.0	3.55	2.5	2.5	5.3	3.75	2.5	5.3	3.75	2.5	5.3	3.75	2.5	5.3	3.75	2.5
8-252-040	1	8.0	16.0	4.0	8.0	5.60	4.0	4.0	8.5	6.00	4.0	8.5	6.00	4.0	8.5	6.00	4.0	8.5	6.00	4.0
8-252-067	1 1/4	12.0	24.0	6.7	13.4	9.50	6.7	6.7	14.0	10.00	6.7	14.0	10.00	6.7	14.0	10.00	6.7	14.0	10.00	6.7
8-252-080	1 1/4	12.0	24.0	8.0	16.0	11.20	8.0	8.0	16.0	12.00	8.0	16.0	12.00	8.0	16.0	12.00	8.0	16.0	12.00	8.0
8-252-100	1 1/2	15.0	30.0	10.0	20.0	14.00	10.0	10.0	21.2	15.00	10.0	21.2	15.00	10.0	21.2	15.00	10.0	21.2	15.00	10.0
8-252-125	1 3/4	15.0	30.0	12.5	25.0	17.00	12.5	12.5	25.0	18.00	12.5	25.0	18.00	12.5	25.0	18.00	12.5	25.0	18.00	12.5
	2	15.0	30.0	12.5	25.0	17.00	12.5	12.5	25.0	18.00	12.5	25.0	18.00	12.5	25.0	18.00	12.5	25.0	18.00	12.5
8-252-170	2	25.0	50.0	17.0	34.0	23.50	17.0	17.0	35.0	25.00	17.0	35.0	25.00	17.0	35.0	25.00	17.0	35.0	25.00	17.0
	2 1/4	25.0	50.0	18.0	36.0	25.00	18.0	18.0	37.5	26.50	18.0	37.5	26.50	18.0	37.5	26.50	18.0	37.5	26.50	18.0
8-252-200	2 1/2	25.0	50.0	20.0	40.0	28.00	20.0	20.0	42.5	30.00	20.0	42.5	30.00	20.0	42.5	30.00	20.0	42.5	30.00	20.0
8-252-280	2 1/2	32.5	65.0	28.0	56.0	39.00	28.0	28.0	58.0	42.00	28.0	58.0	42.00	28.0	58.0	42.00	28.0	58.0	42.00	28.0
8-252-350	3 1/2	40.0	80.0	35.0	70.0	49.00	35.0	35.0	74.0	52.50	35.0	74.0	52.50	35.0	74.0	52.50	35.0	74.0	52.50	35.0

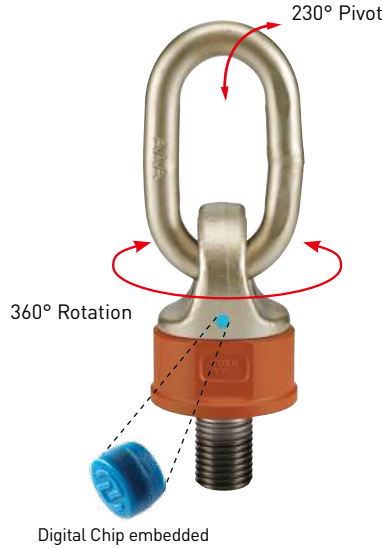
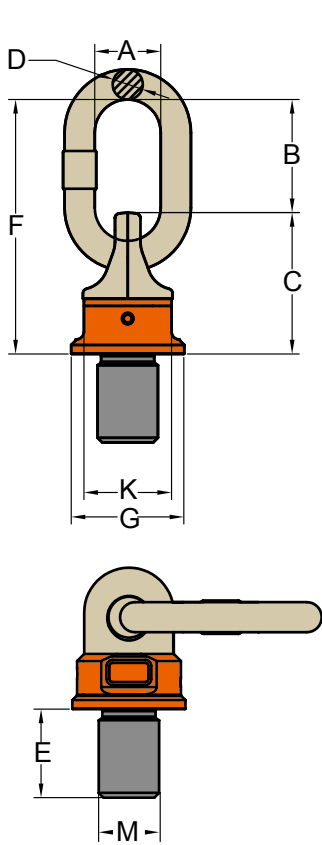

- Pivots to 230°, rotates through 360° due to its unique ball bearing design.
- Manufactured from forged alloy steel, quenched and tempered.
- Tested in accordance with DNV GL-ST-0378.
- Load rated parts are 100% magnaflux crack detected.
- Individual forged parts and batch code links to Test Certificate sheet.
- Bolts are Metric thread.
- Proof tested to 2.5 times the WLL.
- Fatigue rated to 20,000 cycles at 1.5 times the WLL.
- All YOKE Lifting points meet or exceed all the requirements of ASME B30.26.
- Easy to attach or dismantle due to the forged hexagon shaped body of the DA Swivel Point.
- Capable of rotating under load. Do not turn continuously in 90 degree direction at full load.

Digital Chip embedded with Certificate for serial Traceability

- » United States Patent: 10607128
- » UK Patent: 3627396
- » German Patent: 602018032891.2
- » Italy Patent: 3627396
- » Japan Patent: 3219858

Digital DA Swivel Point

Metric Thread (DA-271)



Item No.	Working Load Limit tonnes	Thread version			Dimensions (mm)							Torque in Nm	N.W. kg
		M	E	Pitch DIN13	G	C	K	F	D	B	A		
DA-271-003	0.4	M 8	12	1.25	35	40	30	72	8	32	29	10	0.2
DA-271-004	0.6	M 10	15	1.50	35	40	30	72	8	32	29	10	0.2
DA-271-006	0.7	M 12	18	1.75	40	45	36	95	10	50	35	10	0.3
DA-271-013	1.5	M 16	24	2.00	46	54	41	104	13	50	36	30	0.5
DA-271-020	2.5	M 20	30	2.50	62	68	55	122	13	54	36	70	1.0
DA-271-035	4.0	M 24	36	3.00	78	88	70	154	19	66	41	150	2.2
DA-271-060	6.0	M 30	45	3.50	90	120	80	206	22	86	50	350	4.5
DA-271-080	10.0	M 36	54	4.00	90	120	80	206	22	86	50	410	4.6
DA-271-120	13.0	M 42	63	4.50	98	122	84	235	25	110	67	550	5.5
DA-271-130	14.0	M 48	72	5.00	98	122	84	235	25	110	67	550	6.1
DA-271-140	20.0	M 52	78	5.00	120	150	94	270	32	120	72	750	10.5
DA-271-160	20.0	M 56	84	5.50	120	150	94	270	32	120	72	800	10.7
DA-271-161	20.0	M 64	96	6.00	120	150	94	270	32	120	72	800	11.6

* Design Factor 4:1



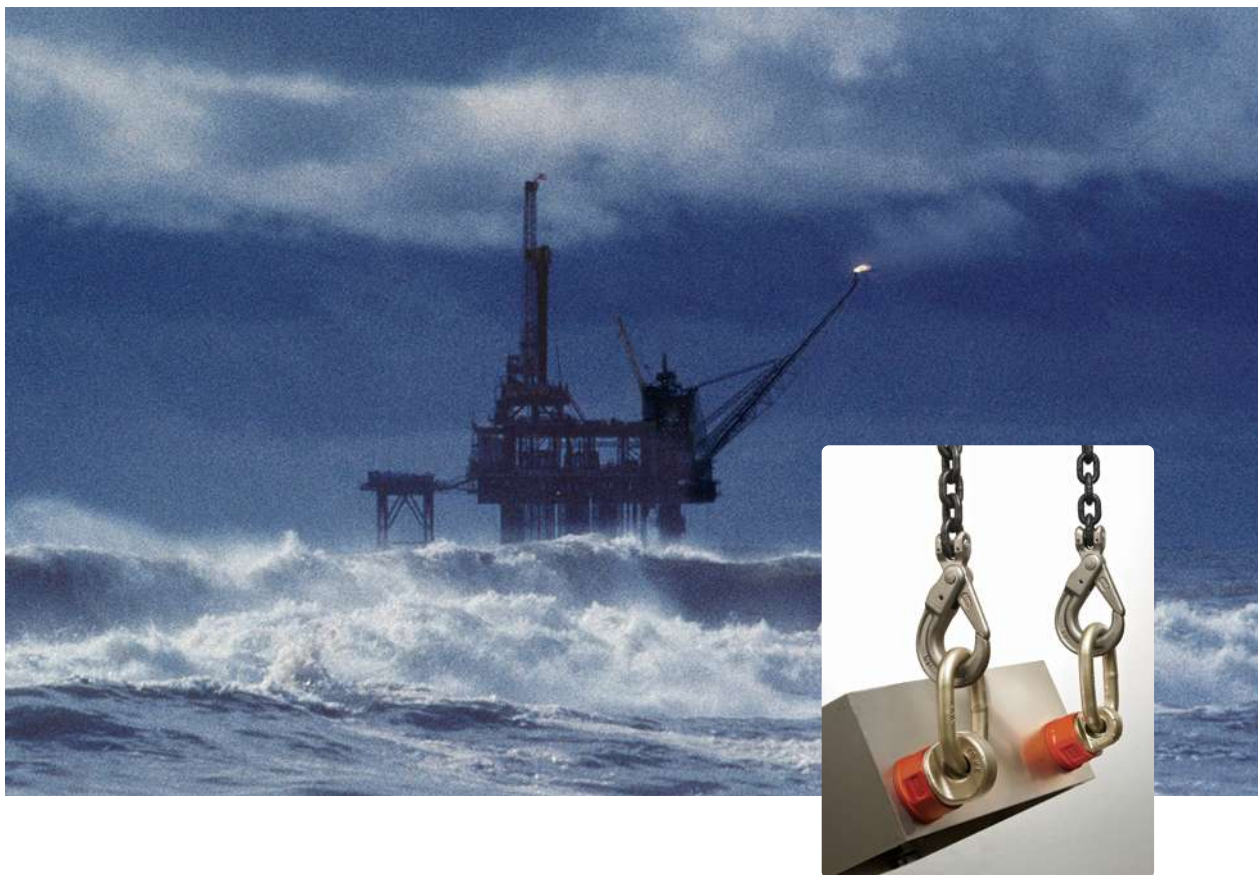

Kind of attachment																				
	Number of legs	Load direction	1	2	1	2	2	2	2	2	2	3-4	3-4	3-4	3-4	3-4	3-4	3-4	3-4	3-4
Item No.	Thread	WLL(t)																		
DA-271-003	M 8	0.6	1.2	0.4	0.8	0.56	0.4	0.4	0.84	0.60	0.4									
DA-271-004	M10	0.9	1.8	0.6	1.2	0.84	0.6	0.6	1.26	0.90	0.6									
DA-271-006	M12	1.2	2.4	0.7	1.4	0.98	0.7	0.7	1.47	1.05	0.7									
DA-271-013	M16	2.6	5.2	1.5	3.0	2.10	1.5	1.5	3.15	2.25	1.5									
DA-271-020	M20	4.0	8.0	2.5	5.0	3.50	2.5	2.5	5.25	3.75	2.5									
DA-271-035	M24	7.0	14.0	4.0	8.0	5.60	4.0	4.0	8.40	6.00	4.0									
DA-271-060	M30	10.0	20.0	6.0	12.0	8.40	6.0	6.0	12.60	9.00	6.0									
DA-271-080	M36	15.0	30.0	10.0	20.0	14.00	10.0	10.0	21.00	15.00	10.0									
DA-271-120	M42	17.0	34.0	13.0	26.0	18.20	13.0	13.0	27.30	19.50	13.0									
DA-271-130	M48	18.0	36.0	14.0	28.0	19.60	14.0	14.0	29.40	21.00	14.0									
DA-271-140	M52	25.0	50.0	20.0	40.0	28.00	20.0	20.0	42.00	30.00	20.0									
DA-271-160	M56	28.0	56.0	20.0	40.0	28.00	20.0	20.0	42.00	30.00	20.0									
DA-271-161	M64	28.0	56.0	20.0	40.0	28.00	20.0	20.0	42.00	30.00	20.0									

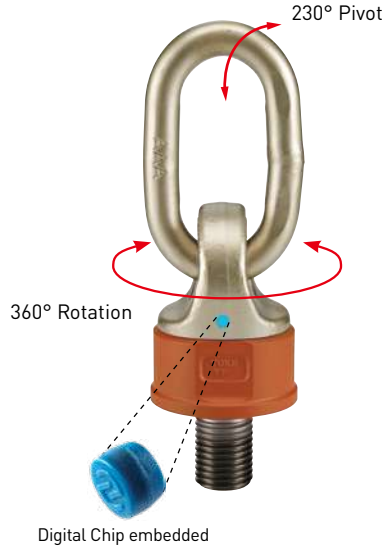
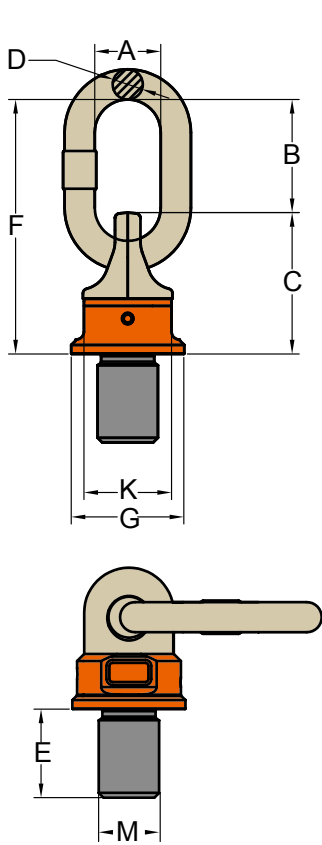

- Pivots to 230°, rotates through 360° due to its unique ball bearing design.
- Manufactured from forged alloy steel, quenched and tempered.
- Tested in accordance with DNV GL-ST-0378.
- Load rated parts are 100% magnaflux crack detected.
- Individual forged parts and batch code links to Test Certificate sheet.
- Bolts are UNC thread.
- Proof tested to 2.5 times the WLL.
- Fatigue rated to 20,000 cycles at 1.5 times the WLL.
- All YOKE Lifting points meet or exceed all the requirements of ASME B30.26.
- Easy to attach or dismantle due to the forged hexagon shaped body of the DA Swivel Point.
- Capable of rotating under load. Do not turn continuously in 90 degree direction at full load.

Digital Chip embedded with Certificate for serial Traceability

- » United States Patent: 10607128
- » UK Patent: 3627396
- » German Patent: 602018032891.2
- » Italy Patent: 3627396
- » Japan Patent: 3219858

Digital DA Swivel Point

UNC Thread (DA-272)



Item No.	Working Load Limit	Thread version			Dimensions (inch)							Torque	
		M	E	TPI	G	C	K	F	D	B	A	in	N.W.
		inch	inch		inch	inch	inch	inch	inch	inch	inch	Nm	lbs
DA-272-006	0.7	1/2	0.75	13UNC	1.57	1.77	1.42	3.74	0.39	1.97	1.38	15	0.7
DA-272-013	1.5	5/8	0.94	11UNC	1.81	2.13	1.61	4.09	0.51	1.97	1.42	45	1.2
DA-272-018	2.0	3/4	1.13	10UNC	1.81	2.68	1.61	4.09	0.51	1.97	1.42	45	1.2
DA-272-020	2.5	7/8	1.31	9UNC	2.44	2.68	2.17	4.80	0.51	2.13	1.42	100	2.2
DA-272-035	4.0	1	1.50	8UNC	3.07	3.46	2.76	6.06	0.75	2.60	1.61	190	4.8
DA-272-060	6.0	1 1/4	1.88	7UNC	3.54	4.72	3.15	8.11	0.87	3.39	1.97	270	9.9
DA-272-080	10.0	1 1/2	2.25	6UNC	3.54	4.72	3.15	8.11	0.87	3.39	1.97	270	10.0
DA-272-120	13.0	1 3/4	2.63	5UNC	3.86	4.80	3.31	9.25	0.98	4.33	2.64	350	12.1
DA-272-130	14.0	2	3.00	4.5UNC	3.86	4.80	3.31	9.25	0.98	4.33	2.64	350	13.5
DA-272-140	20.0	2 1/4	3.38	4.5UNC	4.72	5.91	3.70	10.63	1.26	4.72	2.85	350	23.1
DA-272-160	20.0	2 1/2	3.75	4UNC	4.72	5.91	3.70	10.63	1.26	4.72	2.85	350	23.5

* Design Factor 4:1



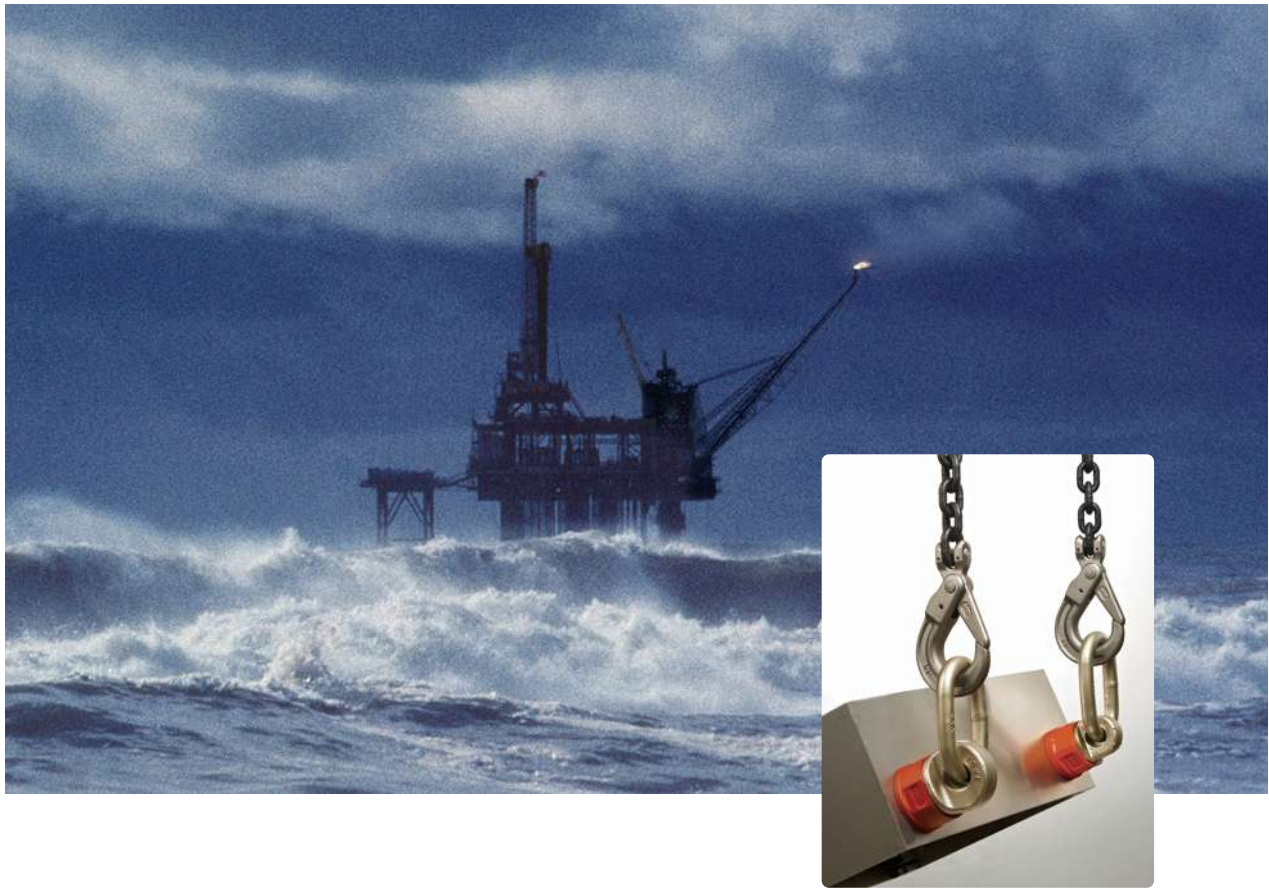

Kind of attachment												
	Number of legs	Thread	0°	0°	90°	90°	0-45°	45°- 60°	unsymm.	0 - 45°	45°- 60°	unsymm.
Item No.	Inch	WLL(t)										
DA-272-006	1/2	1.2	2.4	0.7	1.4	0.98	0.7	0.7	1.47	1.05	0.7	
DA-272-013	5/8	2.6	5.2	1.5	3.0	2.10	1.5	1.5	3.15	2.25	1.5	
DA-272-018	3/4	3.6	7.2	2.0	4.0	2.80	2.0	2.0	4.20	3.00	2.0	
DA-272-020	7/8	4.0	8.0	2.5	5.0	3.50	2.5	2.5	5.25	3.75	2.5	
DA-272-035	1	7.0	14.0	4.0	8.0	5.60	4.0	4.0	8.40	6.00	4.0	
DA-272-060	1 1/4	10.0	20.0	6.0	12.0	8.40	6.0	6.0	12.60	9.00	6.0	
DA-272-080	1 1/2	15.0	30.0	10.0	20.0	14.00	10.0	10.0	21.00	15.00	10.0	
DA-272-120	1 3/4	17.0	34.0	13.0	26.0	18.20	13.0	13.0	27.30	19.50	13.0	
DA-272-130	2	18.0	36.0	14.0	28.0	19.60	14.0	14.0	29.40	21.00	14.0	
DA-272-140	2 1/4	25.0	50.0	20.0	40.0	28.00	20.0	20.0	42.00	30.00	20.0	
DA-272-160	2 1/2	28.0	56.0	20.0	40.0	28.00	20.0	20.0	42.00	30.00	20.0	

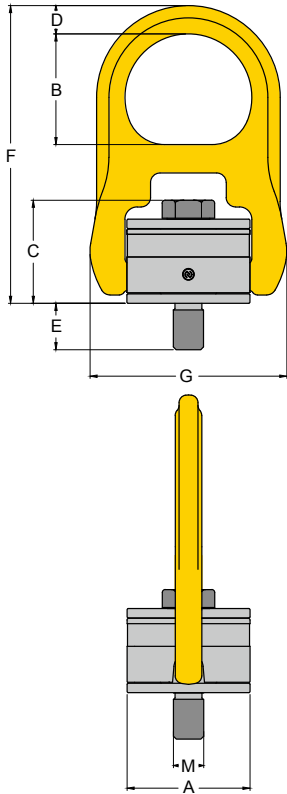

Digital Chip embedded

Digital Chip embedded with Certificate for serial Traceability

- Rotates through 360° and pivots 180°, and simultaneously allows lifting from any direction.
- Manufactured from forged alloy steel, quenched and tempered.
- Manufactured and tested in accordance with EN1677-1.
- Load rated parts are 100% magnaflux crack detected.
- Individual forged parts and cap screw are traceable to Test Certification.
- Bolts are Metric thread.
- Proof tested to 2.5 times the WLL.
- Fatigue rated to 20,000 cycles at 1.5 times the WLL.
- All YOKE Lifting points meet or exceed all the requirements of ASME B30.26.
- Quick and simple assembly, just a tapped hole is required

» United States Patent: 10607128

» UK Patent: 3627396

» German Patent: 602018032891.2

» Italy Patent: 3627396

» Japan Patent: 3219858

» China Patent: ZL 2012 1 0131962.1

» Taiwan Patent: 1468602

Digital Hoist Ring

Metric Thread (8-203)



Kind of attachment

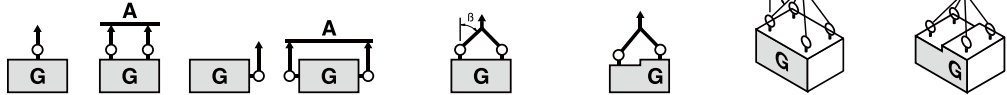

Item No.	Thread	WLL(t)									
		1 leg 0°	2 legs 0°	1 leg 90°	2 legs 90°	2 legs 0-45°	2 legs 45-60°	2 legs unsymm.	3-4 legs 0-45°	3-4 legs 45-60°	3-4 legs unsymm.
8-203-0041	M 8	0.50	1.0	0.50	1.0	0.70	0.50	0.50	1.05	0.75	0.50
8-203-0051	M10	0.55	1.1	0.55	1.1	0.77	0.55	0.55	1.16	0.83	0.55
8-203-0101	M12	1.30	2.6	1.30	2.6	1.82	1.30	1.30	2.73	1.95	1.30
8-203-0191	M16	2.40	4.8	2.40	4.8	3.36	2.40	2.40	5.04	3.60	2.40
8-203-0211	M20	2.70	5.4	2.70	5.4	3.78	2.70	2.70	5.67	4.05	2.70
8-203-0301	M20	3.75	7.5	3.75	7.5	5.25	3.75	3.75	7.88	5.63	3.75
8-203-0421	M24	5.25	10.5	5.25	10.5	7.35	5.25	5.25	11.03	7.88	5.25
8-203-0701	M30	8.75	17.5	8.75	17.5	12.25	8.75	8.75	18.38	13.13	8.75
8-203-0801	M36	10.00	20.0	10.00	20.0	14.00	10.00	10.00	21.00	15.00	10.00
8-203-1001	M36	12.50	25.0	12.50	25.0	17.50	12.50	12.50	26.25	18.75	12.50
8-203-1251	M42	15.60	31.2	15.60	31.2	21.84	15.60	15.60	32.76	23.40	15.60
8-203-1351	M48	16.90	33.8	16.90	33.5	23.66	16.90	16.90	35.49	25.35	16.90



Item No.	Working Load Limit		Thread version			Dimensions						Torque in	N.W.
	tonnes		M	E	Pitch	A	B	C	D	F	G	Nm	kg
	5 : 1	4 : 1	mm		DIN13			mm					
8-203-0041	0.40	0.50	M 8	12	1.25	40	41	38	10	101	65	10	0.4
8-203-0051	0.45	0.55	M10	15	1.50	40	41	39	10	101	65	16	0.5
8-203-0101	1.05	1.30	M12	18	1.75	65	59	52	15	157	104	38	1.7
8-203-0191	1.90	2.40	M16	24	2.00	65	59	55	15	157	104	81	1.8
8-203-0211	2.15	2.70	M20	30	2.50	65	59	57	15	157	104	136	1.8
8-203-0301	3.00	3.75	M20	30	2.50	85	74	67	22	203	134	136	4.0
8-203-0421	4.20	5.25	M24	36	3.00	85	74	69	22	203	134	312	4.2
8-203-0701	7.00	8.75	M30	45	3.50	100	80	77	25	216	160	637	6.6
8-203-0801	8.00	10.00	M36	54	4.00	100	80	81	25	216	160	1005	6.9
8-203-1001	10.00	12.50	M36	54	4.00	120	106	108	36	306	220	1005	15.0
8-203-1251	12.50	15.60	M42	63	4.50	120	106	111	36	306	220	1005	16.0
8-203-1351	13.50	16.90	M48	72	5.00	120	106	115	36	306	220	1350	16.0

Item No.	Working Load Limit		Thread version			Dimensions						Torque in	N.W.
	tonnes		M	E	Pitch	A	B	C	D	F	G	Nm	kg
	5 : 1	4 : 1	mm		DIN13			mm					
8-203-004	0.40	0.50	M 8	17	1.25	40	41	41	10	101	65	10	0.4
8-203-005	0.45	0.55	M10	11	1.50	40	41	43	10	101	65	16	0.5
§ 8-203-005L	0.45	0.55	M10	26	1.50	40	41	43	10	101	65	16	0.5
8-203-010	1.05	1.30	M12	15	1.75	65	59	57	15	157	104	38	1.7
§ 8-203-010L	1.05	1.30	M12	30	1.75	65	59	57	15	157	104	38	1.7
8-203-019	1.90	2.40	M16	20	2.00	65	59	61	15	157	104	81	1.8
§ 8-203-019L	1.90	2.40	M16	35	2.00	65	59	61	15	157	104	81	1.8
8-203-021	2.15	2.70	M20	25	2.50	65	59	65	15	157	104	136	1.8
§ 8-203-021L	2.15	2.70	M20	45	2.50	65	59	65	15	157	104	136	1.9
8-203-030	3.00	3.75	M20	25	2.50	85	74	74	22	203	134	136	4.0
§ 8-203-030L	3.00	3.75	M20	45	2.50	85	74	74	22	203	134	136	5.2
8-203-042	4.20	5.25	M24	26	3.00	85	74	78	22	203	134	312	4.2
§ 8-203-042L	4.20	5.25	M24	56	3.00	85	74	78	22	203	134	312	4.3
8-203-070	7.00	8.75	M30	81	3.50	100	80	77	25	216	160	637	6.6
8-203-110	11.00	13.75	M36	76	4.00	120	106	108	36	306	220	1005	15.0
8-203-125	12.50	15.60	M42	65	4.50	120	106	111	36	306	220	1005	16.0
8-203-135	13.50	16.90	M48	70	5.00	120	106	115	36	306	220	1350	16.0

§ Long Bolts are designed for soft metal work piece.

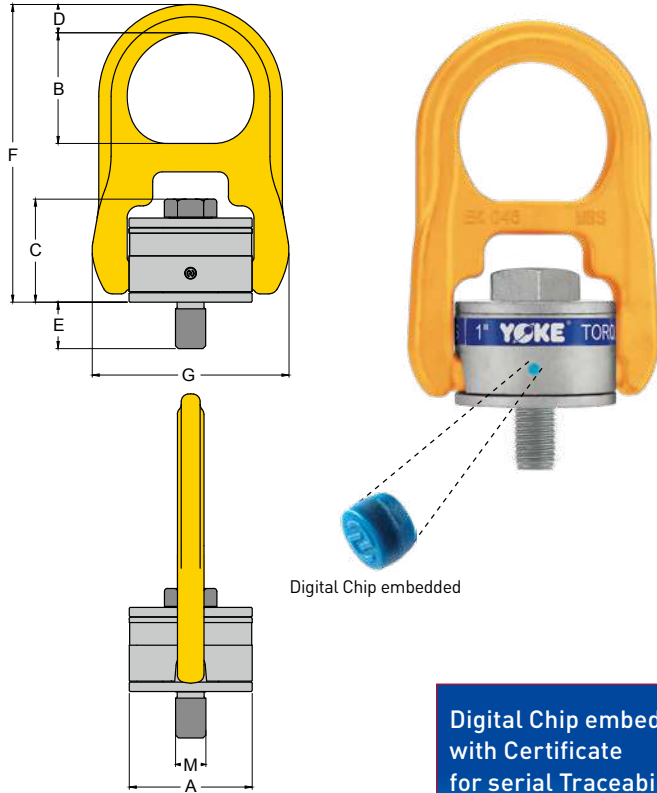

- Rotates through 360° and pivots 180°, and simultaneously allows lifting from any direction.
 - Manufactured from forged alloy steel, quenched and tempered.
 - Manufactured and tested in accordance with EN1677-1.
 - Load rated parts are 100% magnaflux crack detected.
 - Individual forged parts and cap screw are traceable to Test Certification.
 - Bolts are UNC thread.
 - Proof tested to 2.5 times the WLL.
 - Fatigue rated to 20,000 cycles at 1.5 times the WLL.
 - All YOKE Lifting points meet or exceed all the requirements of ASME B30.26.
 - Quick and simple assembly, just a tapped hole is required.
- » United States Patent: 10607128
 - » UK Patent: 3627396
 - » German Patent: 602018032891.2
 - » Italy Patent: 3627396
 - » Japan Patent: 3219858
- » China Patent: ZL 2012 1 0131962.1
 - » Taiwan Patent: I468602

Digital Hoist Ring

UNC Thread (8-204)



Kind of attachment	1 leg		2 legs		2 legs		2 legs		3-4 legs		3-4 legs	
	0°	0°	90°	90°	0-45°	45°- 60°	unsymm.	0 - 45°	45°- 60°	unsymm.	unsymm.	
Number of legs	1	2	1	2	2	2	2	3-4	3-4	3-4		
Load direction	0°	0°	90°	90°	0-45°	45°- 60°	unsymm.	0 - 45°	45°- 60°	unsymm.		
Thread	UNC											
Item No.	Inch	WLL(t)										
8-204-0041	5/16	0.36	0.72	0.36	0.72	0.50	0.36	0.36	0.76	0.54	0.36	
8-204-0051	3/8	0.45	0.90	0.45	0.90	0.63	0.45	0.45	0.95	0.68	0.45	
8-204-0101	1/2	1.10	2.20	1.10	2.20	1.54	1.10	1.10	2.31	1.65	1.10	
8-204-0191	5/8	1.80	3.60	1.80	3.60	2.52	1.80	1.80	3.78	2.70	1.80	
8-204-0211	3/4	2.20	4.40	2.20	4.40	3.08	2.20	2.20	4.62	3.30	2.20	
8-204-0301	3/4	3.10	6.20	3.10	6.20	4.34	3.10	3.10	6.51	4.65	3.10	
8-204-0421	7/8	3.60	7.20	3.60	7.20	5.04	3.60	3.60	7.56	5.40	3.60	
8-204-0451	1	4.50	9.00	4.50	9.00	6.30	4.50	4.50	9.45	6.75	4.50	
8-204-0701	1 1/4	6.80	13.60	6.80	13.60	9.52	6.80	6.80	14.28	10.20	6.80	
8-204-1251	1 1/2	10.90	21.80	10.90	21.80	15.26	10.90	10.90	22.89	16.30	10.90	
8-204-1351	2	13.60	27.20	13.60	27.20	19.04	13.60	13.60	28.56	20.40	13.60	



Item No.	Working Load Limit		Thread version			Dimensions						Torque	N.W.
	lbs		M	E	TPI	A	B	C	D	F	G		
	5:1	4:1	inch	inch				mm			ft.lbs	lbs	
8-204-0041	800	1000	5/16	0.47	18UNC	1.57	1.61	1.61	0.35	4.02	2.56	7	0.9
8-204-0051	1000	1250	3/8	0.56	16UNC	1.57	1.61	1.69	0.35	4.02	2.56	12	0.9
8-204-0101	2500	3125	1/2	0.75	13UNC	2.56	2.32	2.24	0.59	6.26	4.13	28	3.7
8-204-0191	4000	5000	5/8	0.94	11UNC	2.56	2.32	2.38	0.59	6.26	4.13	60	4.0
8-204-0211	5000	6250	3/4	1.13	10UNC	2.56	2.32	2.51	0.59	6.26	4.13	100	4.0
8-204-0301	7000	8750	3/4	1.13	10UNC	3.35	2.87	2.87	0.87	8.03	5.28	100	8.8
8-204-0421	8000	10000	7/8	1.31	9UNC	3.35	2.87	3.07	0.87	8.03	5.28	160	9.3
8-204-0451	10000	12500	1	1.50	8UNC	3.35	2.87	3.07	0.87	8.03	5.28	230	9.5
8-204-0701	15000	18750	1 1/4	1.88	7UNC	3.95	3.15	3.06	1.00	8.58	6.30	470	14.4
8-204-1251	24000	30000	1 1/2	2.25	6UNC	4.72	4.17	4.29	1.41	12.09	8.66	800	35.1
8-204-1351	30000	37500	2	3.00	4.5UNC	4.72	4.17	4.54	1.41	12.09	8.66	1100	35.2

Item No.	Working Load Limit		Thread version			Dimensions						Torque	N.W.
	lbs		M	E	TPI	A	B	C	D	F	G		
	5:1	4:1	inch	inch				mm			ft.lbs	lbs	
8-204-004	800	1000	5/16	0.71	18UNC	1.57	1.61	1.61	0.35	4.02	2.56	7	0.9
8-204-005	1000	1250	3/8	0.71	16UNC	1.57	1.61	1.69	0.35	4.02	2.56	12	0.9
8-204-010	2500	3125	1/2	0.75	13UNC	2.56	2.32	2.24	0.59	6.26	4.13	28	3.7
8-204-010L	2500	3125	1/2	1.26	13UNC	2.56	2.32	2.24	0.59	6.26	4.13	28	3.7
8-204-019	4000	5000	5/8	0.74	11UNC	2.56	2.32	2.38	0.59	6.26	4.13	60	4.0
8-204-019L	4000	5000	5/8	1.75	11UNC	2.56	2.32	2.38	0.59	6.26	4.13	60	4.0
8-204-021	5000	6250	3/4	1.24	10UNC	2.56	2.32	2.51	0.59	6.26	4.13	100	4.0
8-204-021L	5000	6250	3/4	1.73	10UNC	2.56	2.32	2.51	0.59	6.26	4.13	100	4.2
8-204-030	7000	8750	3/4	0.87	10UNC	3.35	2.87	2.87	0.87	8.03	5.28	100	8.8
8-204-030L	7000	8750	3/4	1.87	10UNC	3.35	2.87	2.87	0.87	8.03	5.28	100	9.5
8-204-042	8000	10000	7/8	1.38	9UNC	3.35	2.87	3.07	0.87	8.03	5.28	160	9.3
8-204-042L	8000	10000	7/8	2.37	9UNC	3.35	2.87	3.07	0.87	8.03	5.28	160	9.7
8-204-045	10000	12500	1	1.38	8UNC	3.35	2.87	3.07	0.87	8.03	5.28	230	9.5
8-204-045L	10000	12500	1	2.37	8UNC	3.35	2.87	3.07	0.87	8.03	5.28	230	10.1
8-204-070	15000	18750	1 1/4	2.25	7UNC	3.95	3.15	3.06	1.00	8.58	6.30	470	14.5
8-204-125	24000	30000	1 1/2	2.17	6UNC	4.72	4.17	4.29	1.41	12.09	8.66	800	35.2
8-204-135	30000	37500	2	3.01	4.5UNC	4.72	4.17	4.54	1.41	12.09	8.66	1100	35.2





Anchor Point for Personal Protective Equipment



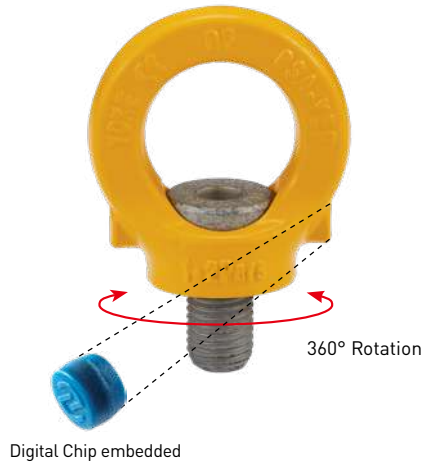
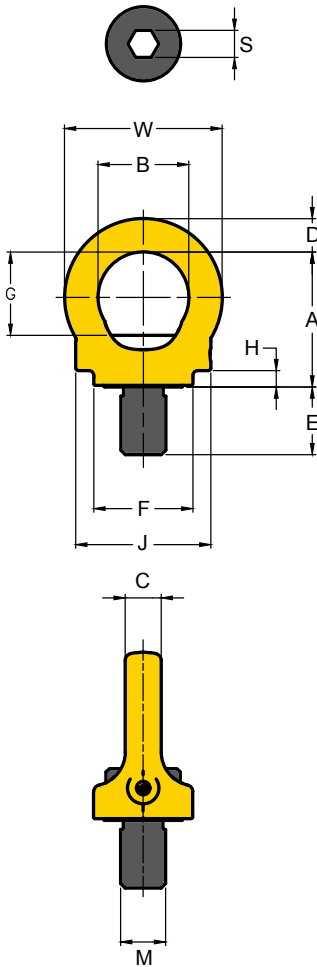

Anchor Point for Personal Protective Equipment

Digital Chip embedded with Certificate for serial Traceability

- Rotates through 360° adjustable in the direction of the load.
- Manufactured from forged alloy steel, quenched and tempered.
- Tested in accordance with EN795 or TS16415.
- Certified by PSA of DGUV.
- Load rated parts are 100% magnaflux crack detected.
- Individual forged parts and cap screw are traceable to Test Certification.
- Passed 22.2 KN/person Load testing.
- Passed 100kg or 150 kg dynamic fall testing (EU standard is 100 kg).
- Meets all requirements of the German BG BAU (Employer's insurance association of the building industry).
- Meets all requirements of DIN EN795, DIN EN50308, OSHA1926.502.
- Acc. to DIN EN 365 including statement for the number of load bearing persons is 1-2 persons.
- YOKE yellow powder coating for high visibility.
- PSA - Lifting point to be as an anchor point for personal protective equipment.

- » Mexico Patent: 3423
- » Japan Patent: 3192016"
- » China Patent: ZL 2014 2 0228663.4
- » China Patent: ZL 2012 1 0131962.1
- » Taiwan Patent: 1468602
- » United States Patent: 10607128
- » UK Patent: 3627396
- » German Patent: 602018032891.2
- » Italy Patent: 3627396
- » Japan Patent: 3219858

Digital PSA-YEP

Metric (8-281)

Item No.	Working Load Limit	Thread version	Dimensions(mm)											Torque in Nm	N.W. kg
			M	A	B	C	D	E	F	G	H	J	S		
8-281-007	1 Pers	M12x1.75	45	30	10	11	18	33	29	5	45	8	52	10	0.2
8-281-015	1-2 Pers	M16x2.0	52	35	14	13	24	35	33	8	52	10	61	30	0.3
8-281-023	1-2 Pers	M20x2.5	60	40	16	15	30	44	37	7	60	12	70	70	0.6

Item No.	Working Load Limit	Thread version	Dimensions(inch)											Torque in ft. lbs	N.W. lbs
			M	A	B	C	D	E	F	G	H	J	S		
8-281-007	1 Pers	M12x1.75	1.8	1.2	0.4	0.4	0.7	1.3	1.1	0.2	1.8	0.3	2.0	7.4	0.4
8-281-015	1-2 Pers	M16x2.0	2.0	1.4	0.6	0.5	0.9	1.4	1.3	0.3	2.0	0.4	2.4	22.1	0.7
8-281-023	1-2 Pers	M20x2.5	2.4	1.6	0.6	0.6	1.2	1.7	1.5	0.3	2.4	0.5	2.8	51.7	1.3



