

WARNING

DO NOT EXCEED WORKING LOAD LIMIT.
USE CERTIFIED RIGGING WITH RIGHT SIZE OF WIRE ROPE



Safe Lifters

Tel +91 20 66013783 / 84 / 85 / 86
Fax +91 20 26350832
Email : safelifters@eth.net

US Type Forged Wire Rope Clamp

FF-C-450 TYPE 1 CLASS1



SL-450

- Each clamps has a product Identification Code for Material traceability, "SL", and a size forged into it.
- Entire Clamps are galvanized / Powder Coated to resist corrosive and rusting action.
- Only Genuine SL Clamps have a Red colour for instant recognition.
- All Clamps have rolled threads and extra heavy nuts.

Rope Size		Dimensions (mm)								Min No. of Clamps	Amt. of Rope to Turn Back in (cm)
(In.)	(mm)	A	B	C	D	E	F	G	H		
3/8	9-10	11.2	38.1	19.1	25.4	23.1	19.2	41.4	49.3	2	16.5
1/2	13	12.7	47.8	25.4	30.2	28.7	22.4	48.5	58.0	3	29.2
5/8	16	14.2	60.5	31.8	33.3	34.0	23.9	52.5	63.5	3	30.5
3/4	18-20	15.8	70.0	36.6	38.1	35.8	26.9	57.0	72.0	4	46
7/8	22	19.1	79.5	41.2	44.5	40.4	31.8	62.0	80.5	4	48
1	24-26	19.1	89.0	46.0	47.8	45.2	31.8	67.0	88.0	5	66
1 1/8	28-30	19.1	98.5	51.0	51.0	48.5	31.8	71.5	91.0	6	86
1 1/4	32-34	22.4	108	54.0	58.5	55.5	36.6	79.5	105	7	112
1 3/8	36	22.4	118	58.5	60.5	58.5	36.6	79.5	106	7	112
1 1/2	38-40	22.4	125	60.5	65.5	62.0	36.6	86.5	113	8	137
1 3/4	44-46	28.7	146	70.0	77.5	74.5	46.0	97.0	134	8	155
2	48-52	31.8	164	76.0	86.0	83.5	51.0	113	149	8	180

Specifications given are indicative and are subject to change.

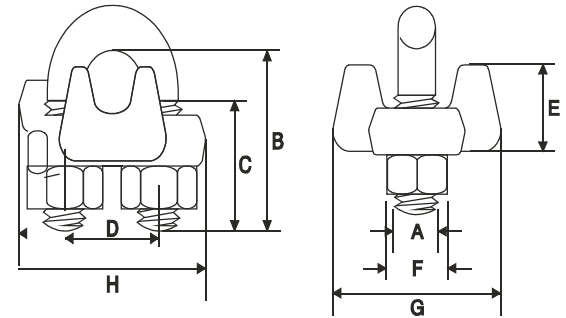

US Type Malleable Wire Rope Clamp

FF-C-450 TYPE 1 CLASS2



SL-451

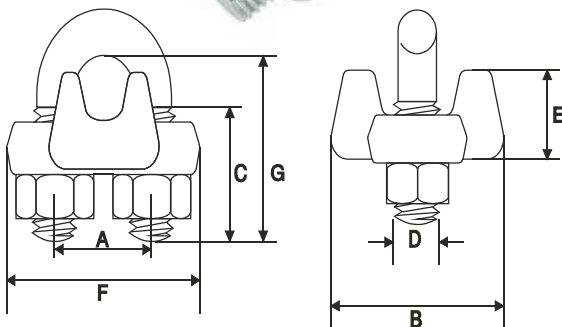

Size	Dimensions(Inches)						
in	D	G	C	A	E	B	F
1/8	1/4	13/16	1/2	1/2	7/16	1/2	15/16
3/16	1/4	31/32	5/8	9/16	1/2	9/16	1 1/16
1/4	5/16	17/32	7/8	11/16	5/8	11/16	1 3/8
5/16	5/16	17/32	7/8	11/16	11/16	11/16	1 3/8
3/8	3/8	15/8	1	7/8	13/16	7/8	1 5/8
7/16	3/8	15/8	1	7/8	13/16	15/16	1 5/8
1/2	7/16	2	1 1/4	1	1 1/16	1	1 7/8
9/16	1/2	2 5/16	1 15/32	1 3/16	1 3/16	1 1/8	2 3/16
5/8	1/2	2 5/16	1 15/32	1 5/16	1 5/16	1 1/8	2 3/16
3/4	9/16	2 9/16	1 3/4	1 1/2	1 1/2	1 1/4	2 7/16
7/8	5/8	3 1/16	1 13/16	1 3/4	1 3/4	1 3/4	2 7/8
1	5/8	3 3/8	2 1/16	1 15/16	1 15/16	2	3
1 1/8	3/4	3 7/8	2 3/16	2 3/16	2 3/16	2 1/8	3 7/16
1 1/4	3/4	3 7/8	2 3/16	2 3/8	2 3/8	2 1/2	3 7/16
1 3/8	7/8	4 1/2	2	2 7/8	2 7/8	3 1/8	4 3/16
1 1/2	7/8	4 1/2	2	3	3	3 1/4	4 1/4

Specifications given are indicative and are subject to change.